



NOTE: The following instructions provide general guidelines for product installation. For additional information consult the applicable electrical codes or contact factory directly for support before attempting anything with uncertainty.

CAUTION: Do not assemble fixture runs on floor.

WARNING: Risk of fire and electrical shock. **DISCONNECT POWER AT ELECTRICAL PANEL** before installing or servicing this product.

GENERAL SAFETY INSTRUCTIONS:

1. Read all instructions prior to installing this fixture.
2. This product must be installed in accordance with the applicable installation code by a person familiar with the construction and operation of the product and the hazards involved.
3. All wiring must be performed by a qualified electrician in accordance with national and local building and electrical codes.
4. This fixture must be suitably grounded for your protection against shock hazards and to assure proper operation.
5. Make sure that the power source conforms to the requirements of this fixture.

Specifications and design subject to change without notice.

PARTS LIST

MAIN PARTS

- A. Luminaire Enclosure
- B. Wall Mounting Plate
- C. End Plate
- D. Lens

OTHER PARTS

- Reflector/LED Assembly
- Electrical Box (by others)
- Fasteners (by others)

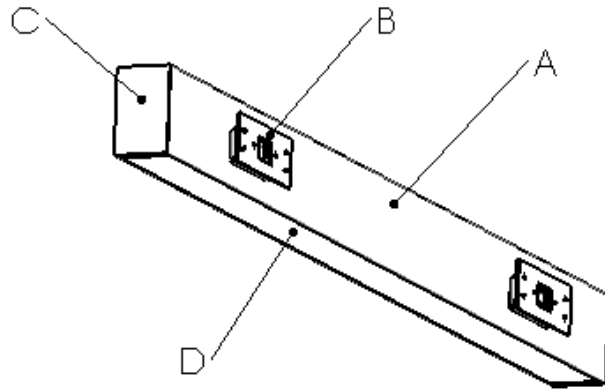

REQUIRED TOOLS

DRILL	#8 PHILLIPS BIT	#8 PHILLIPS SCREWDRIVER	WRENCH

Important: Use clean gloves to avoid adding oil/dirt to optics surface. Avoid scratching optics by using installation tools with soft plastic rounded edges

WIRING DIAGRAMS

STANDARD WIRING	WITH OPTIONAL EMERGENCY PACK
<p>(5) LEADS</p> <ul style="list-style-type: none"> BLACK — LINE WHITE — NEUTRAL BARE — GROUND VIOLET — DIM(+) GREY — DIM(-) 	<ul style="list-style-type: none"> BLACK — LINE WHITE — NEUT BARE — GROUND

Specifications and design subject to change without notice.

WITH OPTIONAL BATTERY PACK

(4) LEADS

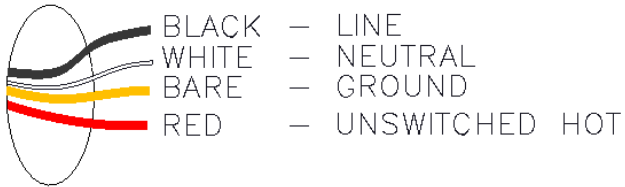

Specifications and design subject to change without notice.

STEP-BY-STEP INSTRUCTIONS

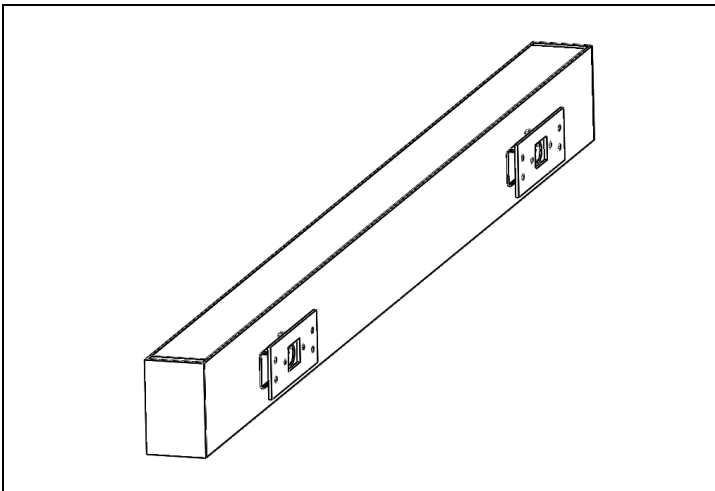

STEP 1. Remove fixture packaging; note marked supply wires coming out at the back of the luminaire.

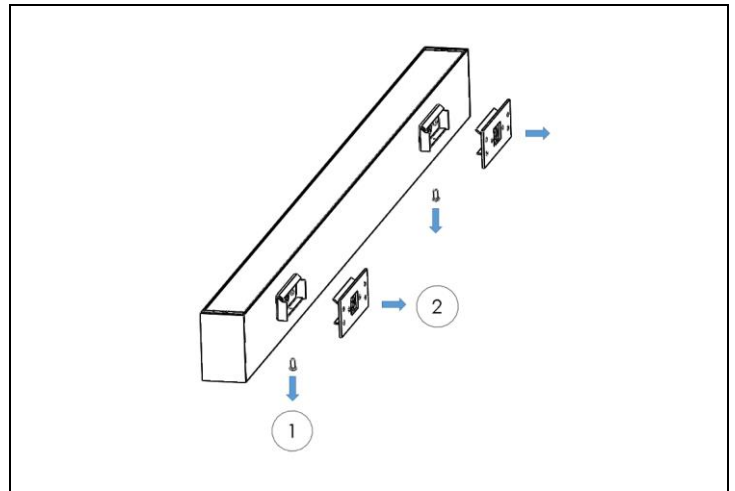

STEP 2. Remove the locking screws from each of the (2) wall brackets. Detach the wall mount plates (B) from the luminaire enclosure. Use mounting plate and mounting location diagram to mark location of mounting fasteners (by others).

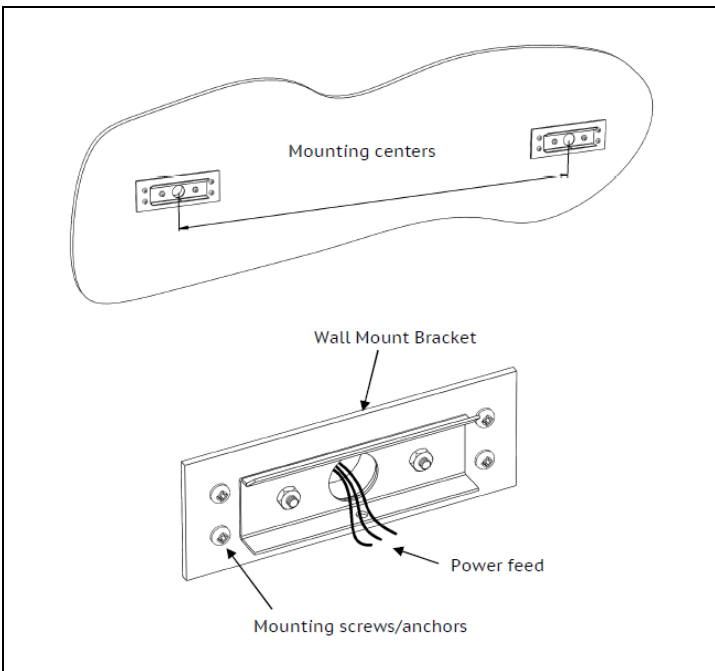

STEP 3. Install both wall mounting plates using (4) fasteners for each plate. Make sure the plate on wire entry side completely seals the electrical box and the two plates are installed at the same horizontal level. Route wires through the wall mount plate.

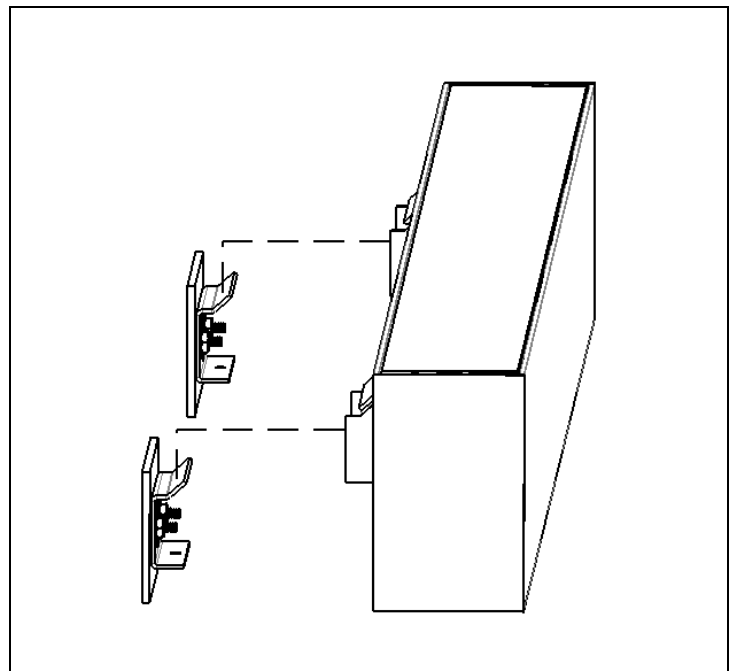

STEP 4. Attach luminaire to wall plates.

Specifications and design subject to change without notice.

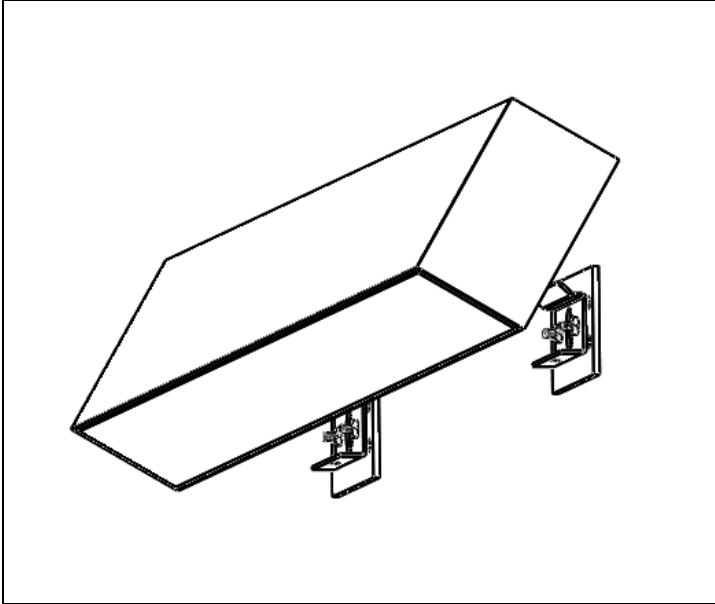

STEP 5. With the luminaire attached to the wall plates and rotated about 45 degrees, perform electrical wiring. Optional emergency ballast must be fed from the same branch circuit as the AC ballast.

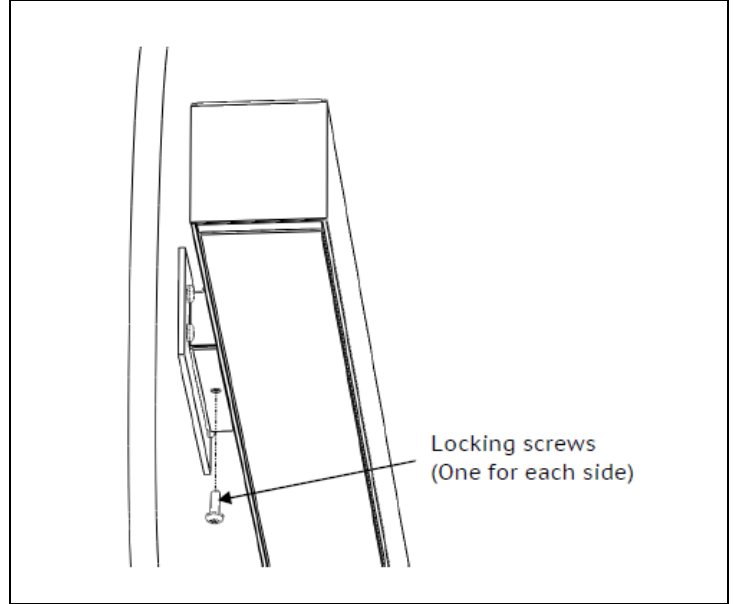

STEP 6. Lock fixture to wall mounts by re-attaching locking screws.

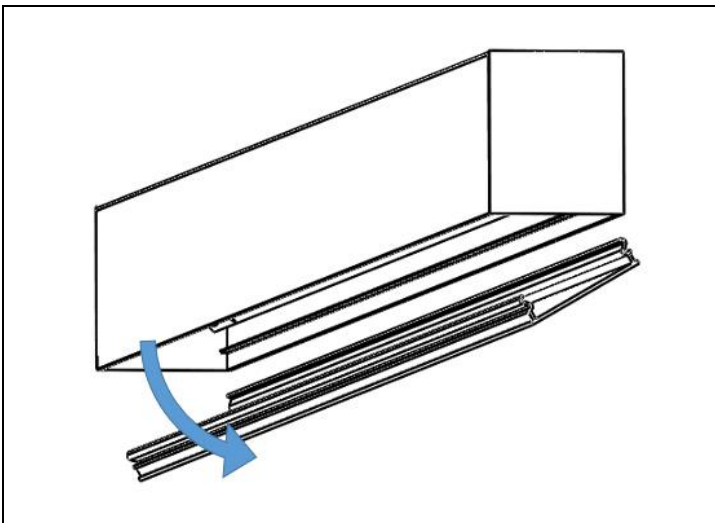

STEP 7. Perform this step only to gain access to optional emergency/battery pack. Remove lens (C) starting at one end. Pull one side first, rotate and detach. Keep lens.

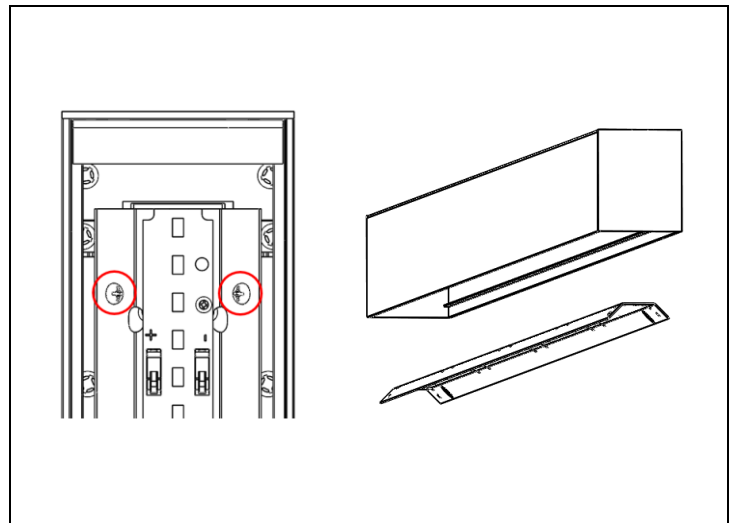

STEP 8. Perform this step only to gain access to optional emergency/battery pack. Remove reflector mounting screws and reflector/LED assembly. Note fixtures with optional emergency pack have a test switch and indicator light mounted on the reflector. Re-attach reflector with (2) mounting screws.

Specifications and design subject to change without notice.

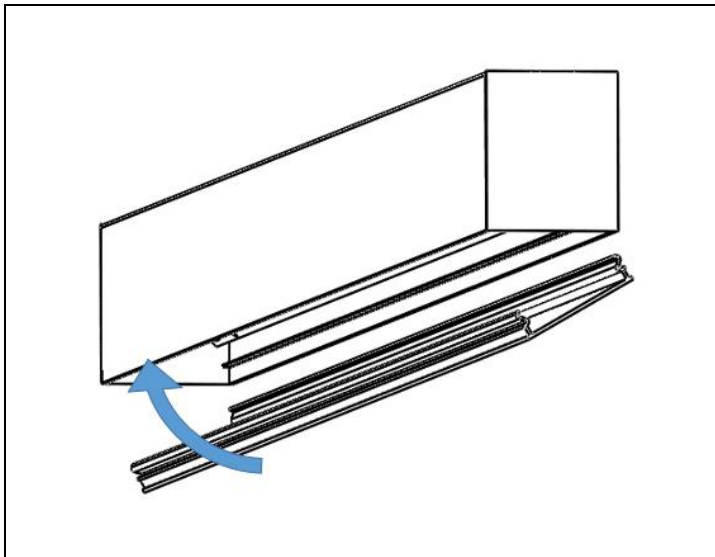

STEP 9. Perform this step only to gain access to optional emergency/battery pack. Re-attach lens. Start with one side first and close the other side starting from the corner. Make sure lens gaskets are in place and compressed between lens and fixture housing.

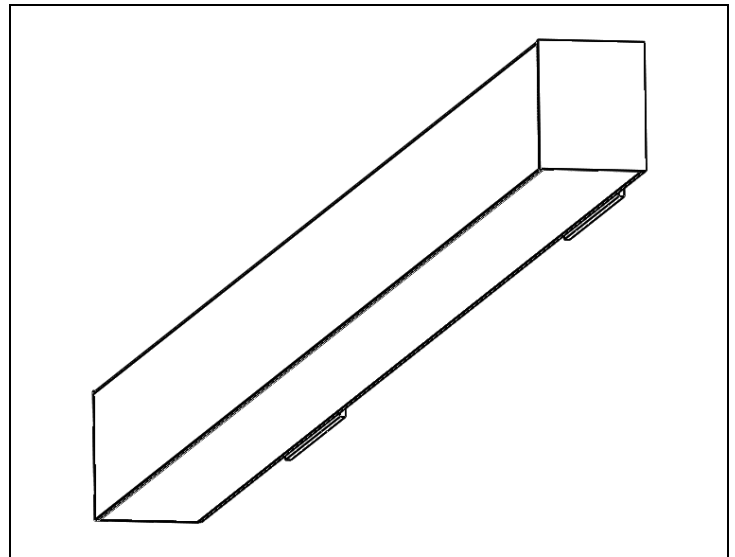

STEP 10. Installed fixture.

Specifications and design subject to change without notice.

JOINING INSTRUCTIONS

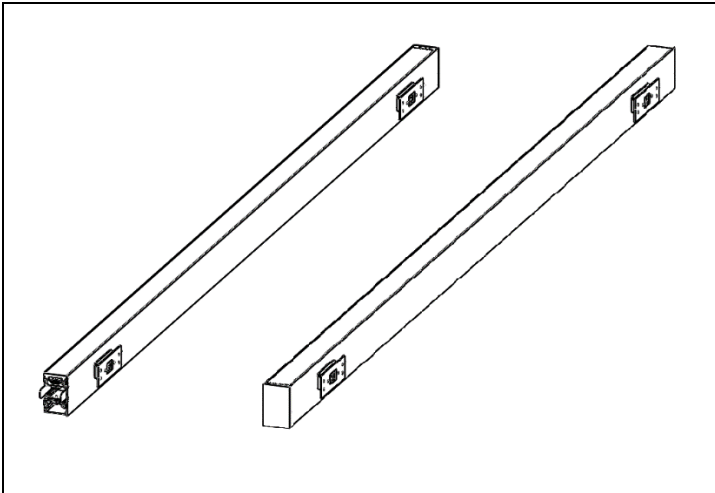

STEP 1. Remove fixture packaging; note marked supply wires coming out at the back of the luminaire.

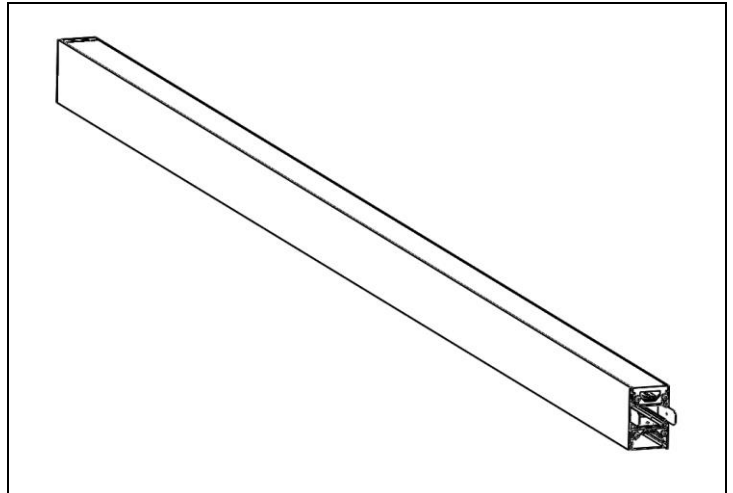

STEP 2. Install Start luminaire following standard installation instructions. Do not apply power to the fixture.

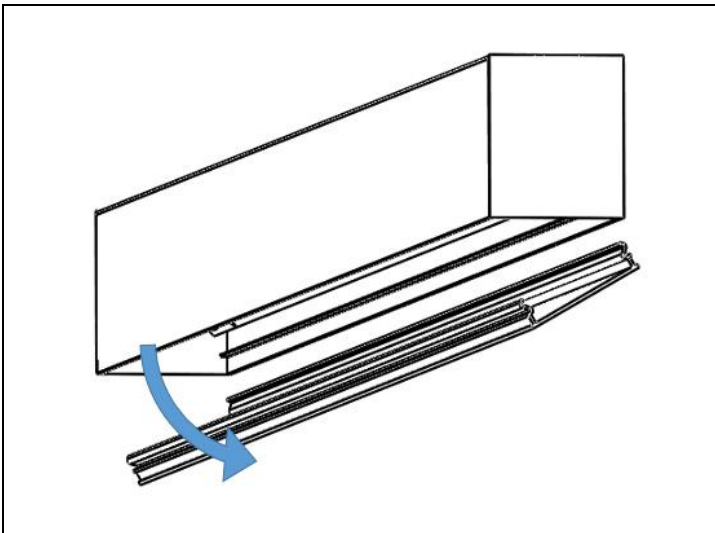

STEP 3. For both the start fixture and the next fixture to be joined (mid/end), remove lens starting at one end. Pull one side first, rotate and detach. Keep lens.

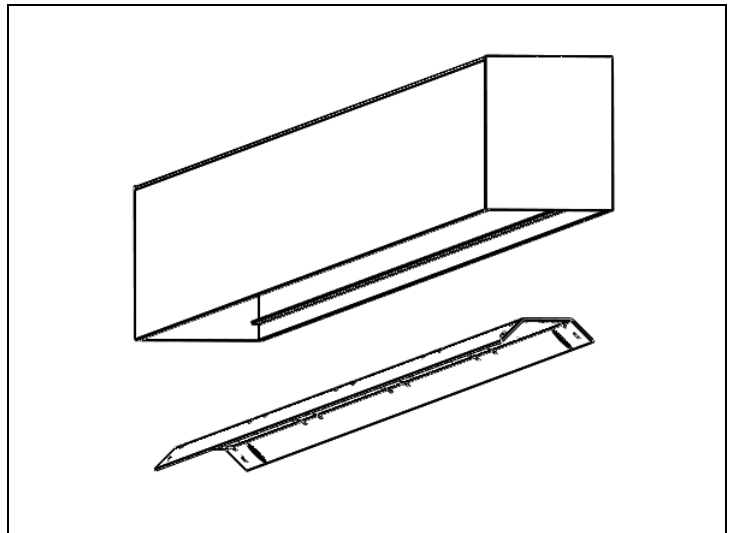

STEP 4. For both the start fixture and the next fixture to be joined (mid/end), remove reflector mounting screws and reflector/LED assembly. Note fixtures with optional emergency pack have a test switch and indicator light mounted on the reflector.

Specifications and design subject to change without notice.

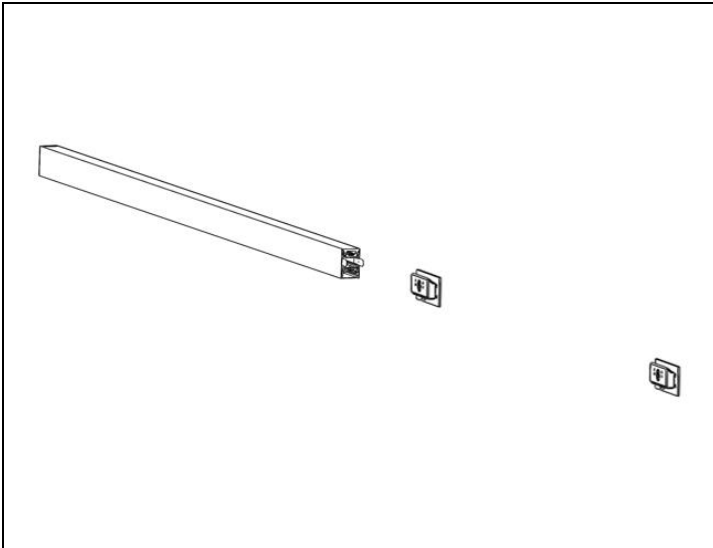

STEP 5. Install both wall mounting plates for the next fixture as per standard instructions.

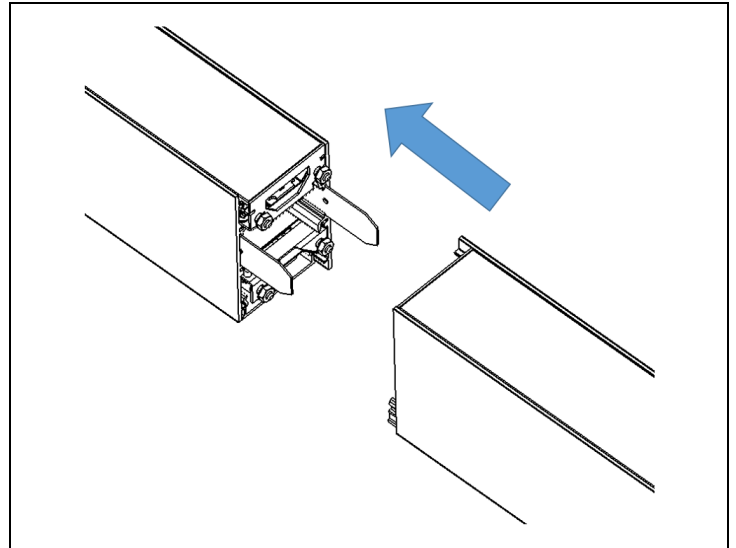

STEP 6. Align mid/end fixture with the start and slide into place. Secure with screws. Perform all necessary wiring between fixtures.

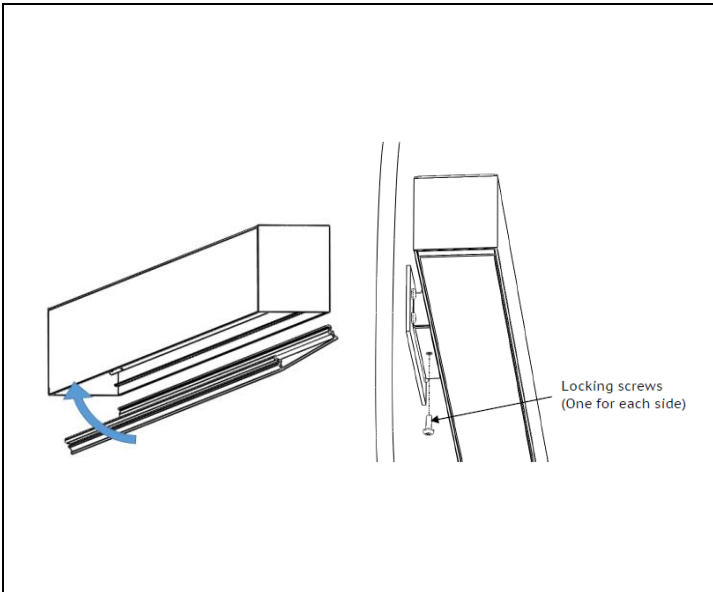

STEP 7. Re-install reflector assemblies and lenses. Finish mounting fixture with locking screws.

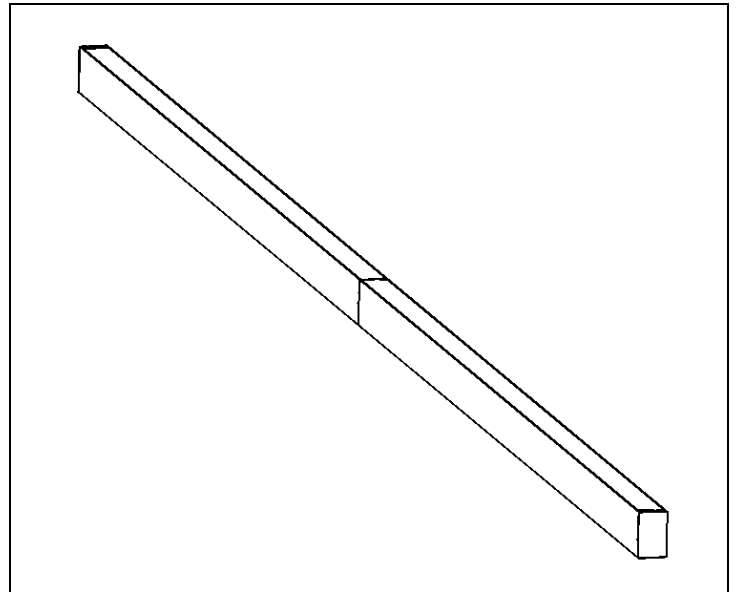

STEP 8. Joined luminaires. Complete remaining fixtures installation as needed.

Specifications and design subject to change without notice.

MAINTENANCE

REQUIRED TOOLS:

- Plastic / Latex Gloves
- Screwdriver

Important: Use clean gloves to avoid adding oil/dirt to reflector surface. Avoid scratching reflector surface by using installation tools with soft plastic rounded edges.

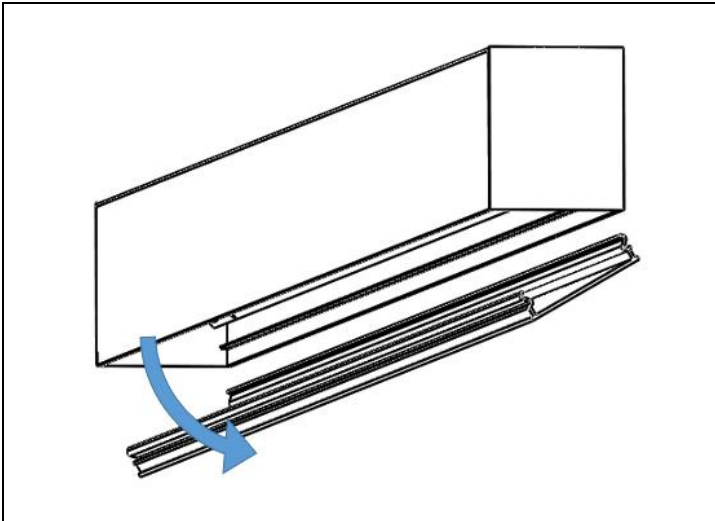

STEP 1. For LED board maintenance, remove lens (C) starting at one end. Pull one side first, rotate, and detach. The LED boards are now accessible

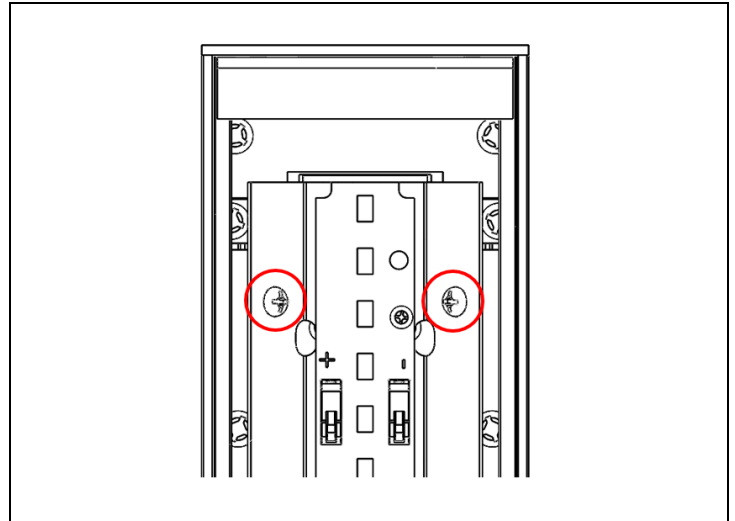

STEP 2. For driver maintenance, first unscrew the reflector assembly.

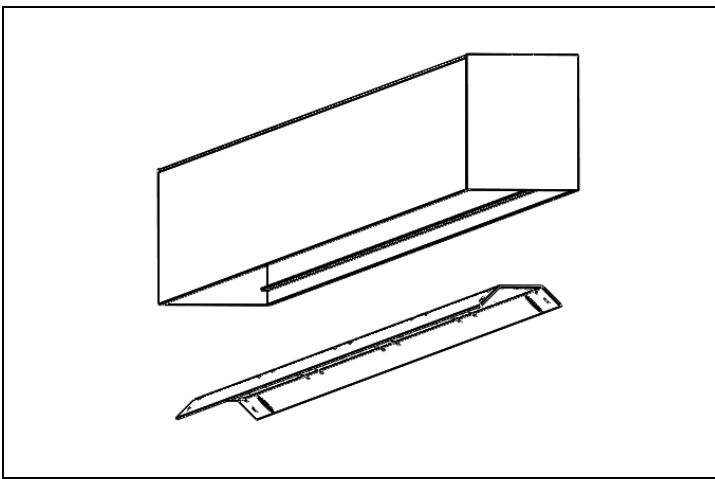

STEP 3. Remove reflector assembly from unit.

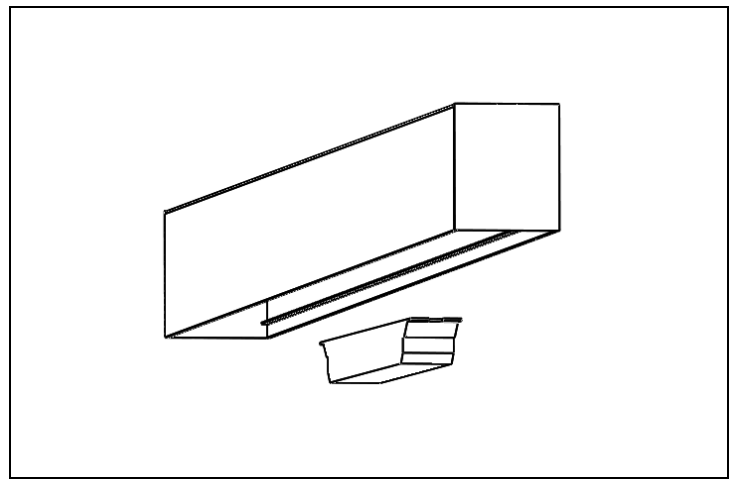

STEP 4. Remove and service driver as required.

Specifications and design subject to change without notice.