

RAIL 4 RM4DI

LED . PENDANT . DIRECT/INDIRECT

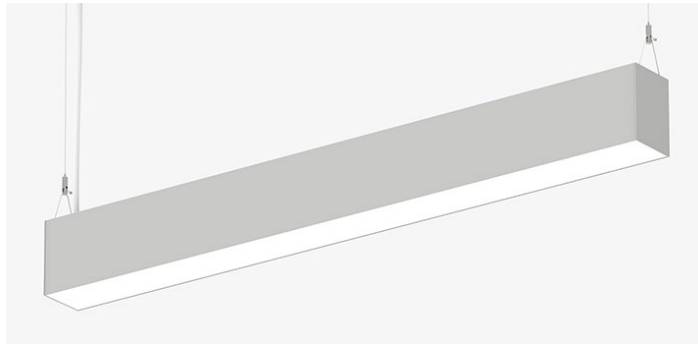

PART #:	
PREP BY:	DATE:
PROJECT:	
NOTES:	
APPROVAL SIGNATURE:	DATE (DD/MM/YYYY):

PERFORMANCE SUMMARY @ 3500K		MBMB	MBMD	MRMD	MM
L3					
Lumens per foot	80 CRI	1274	1290	1300	1352
	90 CRI	1115	1129	1138	1183
Distribution (Up / Down %)		51 / 49	53 / 47	51 / 49	51 / 49
Wattage per foot		12.1	12.1	12.1	12.1
Efficacy	80 CRI	106	107	107	112
	90 CRI	92	93	94	98
L70 Estimate (h)		≥ 60,000 hrs			

See page 2 for the complete Light Level Performance chart.

FEATURES

- 3/4 " drop lens with seamless lines of light without pixels or shadows
- Integral drivers
- Option for daylight harvesting, occupancy sensing, dimming control and emergency lighting
- Optional Illuminated by BIOS version for Healthy Lighting and Well Building Applications

ORDERING LOGIC

Example Part Number: RM4DI-2L35K-12-MBMB-W-L31-PA18-1-D-90

1. SERIES	2. COLOR TEMP	3. LENGTH	4. PATTERN ¹	5. OPTICS	6. FINISH	
RM4DI	2L30K 3000K 2L35K 3500K 2L40K 4000K	2 2 ft 3 3 ft 4 4 ft 5 5 ft 6 6 ft 7 7 ft 8 8 ft 9 9 ft 10 10 ft 11 11 ft 12 12 ft RA Continuous Rows Replace "A" with length in feet selected on p3 C Custom Length* - None (leave space empty)	GA Square GAxB Rectangle UAxBxC U-Shape LAxB L-Shape C Custom Pattern* - None (leave space empty) Standard Patterns Minimum Lengths Custom Patterns* Lengths and a drawing of custom pattern are required on page 4 Select corner: <input type="checkbox"/> Outside 90° <input type="checkbox"/> Inside 90° 	MBMB Up: Meta Blanc Down: Meta Blanc MBMD Up: Meta Blanc Down: Drop Lens ** MRMD Up: Rise Lens Down: Drop Lens ** MM Up: Meta Ice Down: Meta Ice BWMB Up: Batwing ³ Down: Meta Blanc BWMD Up: Batwing ³ Down: Drop Lens ** BWM Up: Batwing ³ Down: Meta Ice Meta Blanc, Rise & Drop Lens: Opal diffuse lens Meta Ice: High output semi-diffuse lens	SA Satin Aluminum W White B Black C Custom Finish Specify RAL:	
7. LIGHT LEVEL / DRIVER L1 ³ L2 L3 L4	Select Driver below. See Light Level Performance chart on p2.	8. CIRCUITRY 1 1 Circuit UD Up/Down Switching EM Emergency / Night Light B Emergency Battery Pack ²	9. MOUNTING PAA Pendant Aircraft Cable PTA Pendant Aircraft Cable for T-bar Replace "A" with length (inches) selected below. Select Aircraft Cable Length, Canopy Finish & Power Cord Color below	10. VOLTAGE 1 120 V 2 277 V 3 347 V 4 UNV (120 - 277V)	11. CONTROLS / SENSORS - None (leave space empty) D Wattstopper Daylight Sensor O Wattstopper Occupancy Sensor DO Wattstopper Daylight and Occupancy Sensors	12. OPTIONS 90 90 CRI, High R9 BS BIOS Static BD BIOS Dynamic - None (leave space empty)

*Consult factory. | ** Rise lens and Drop lens are not available with patterns. | ¹ Pattern record drawings showing mounting locations will be sent out upon order. | ² Battery operates 4ft direct sections only. | ³ Not available with BIOS.

Select Driver:

- Factory option 0-10V, 1% Dimming
- LHE** Lutron H-Series Hi-lume 1% EcoSystem LED Driver
- LA2** Lutron A-Series Hi-lume 1% 2-wire LED Driver
- L5E** Lutron 5-Series EcoSystem LED Driver

Select Aircraft Cable Length:

Total adjustment range is 6" up & down for each standard length. All other lengths are considered custom unless otherwise stated.

Select:	Imperial (in)	Metric (mm)
<input type="checkbox"/>	12	305
<input type="checkbox"/>	18	460
<input type="checkbox"/>	24	610
<input type="checkbox"/>	30	760
<input type="checkbox"/>	36	915
<input type="checkbox"/>	42	1067
<input type="checkbox"/>	48	1220

Select:	Imperial (in)	Metric (mm)
<input type="checkbox"/>	54	1372
<input type="checkbox"/>	60	1525
<input type="checkbox"/>	72	1830
<input type="checkbox"/>	96	2440
<input type="checkbox"/>	120	3050
<input type="checkbox"/>	144	3660
<input type="checkbox"/>	Custom Length: _____	

Select Canopy Finish & Power Cord Color

Canopy	Power Cord
<input type="checkbox"/> White	<input type="checkbox"/> White
<input type="checkbox"/> Black	<input type="checkbox"/> Black*
<input type="checkbox"/> Custom Finish	
RAL: _____	*Consult factory.

Light Level Performance

3500K, 80 CRI, 0-10V Dimming (Standard)

Distribution % (Up / Down)	MBMB (UP: Meta Blanc / DOWN: Meta Blanc)			MBMD (UP: Meta Blanc / DOWN: Drop Lens)			MRMD (UP: Rise Lens / DOWN: Drop Lens)			MM (UP: Meta Ice / DOWN: Meta Ice)		
	Lumens per foot	Wattage per foot	Efficacy (lm/W)	Lumens per foot	Wattage per foot	Efficacy (lm/W)	Lumens per foot	Wattage per foot	Efficacy (lm/W)	Lumens per foot	Wattage per foot	Efficacy (lm/W)
	51 / 49			53 / 47			51 / 49			51 / 49		
L1	749	7.0	107	758	7.0	108	814	6.9	118	794	7.0	113
L2	937	8.9	106	949	8.8	107	956	8.8	109	997	8.9	113
L3	1274	12.1	106	1290	12.1	107	1300	12.1	108	1352	12.1	112
L4	2363	25.0	95	2393	25.0	96	2412	24.2	100	2639	24.2	109

Standard Lumen Adjustment Factor

Color Temp	80 CRI	90 CRI
3000K	0.984	0.880
3500K	1.000	0.875
4000K	1.032	0.879

BIOS 3500K

Distribution % (Up / Down)		MBMB (UP: Meta Blanc / DOWN: Meta Blanc)			MBMD (UP: Meta Blanc / DOWN: Drop Lens)			MRMD (UP: Rise Lens / DOWN: Drop Lens)			MM (UP: Meta Ice / DOWN: Meta Ice)		
		Lumens per foot	Wattage per foot	Efficacy (lm/W)	Lumens per foot	Wattage per foot	Efficacy (lm/W)	Lumens per foot	Wattage per foot	Efficacy (lm/W)	Lumens per foot	Wattage per foot	Efficacy (lm/W)
		51 / 49			53 / 47			51 / 49			51 / 49		
Static	L2	1244	18.9	66	1309	18.9	69	1256	18.9	67	1413	18.9	75
	L3	1659	26.6	62	1746	26.6	66	1675	26.6	63	1885	26.6	71
	L4	2016	34.4	59	2122	34.4	62	2035	34.4	59	2291	34.4	67
Dynamic	L2	1119	18.9	59	1178	18.9	62	1130	18.9	59.9	1272	18.9	67
	L3	1493	26.6	56	1571	26.6	59	1507	26.6	56.6	1696	26.6	64
	L4	1814	34.4	53	1910	34.4	56	1832	34.4	53.3	2062	34.4	60

BIOS Lumen Adjustment Factor (LAF)

Color Temp	LAF
3500K	1.00
4000K	1.05

BIOS Naming Convention Reference

BIOS	Static	
	3500K	35BIOSST
4000K	40BIOSST	
BIOS	Dynamic	
	3500K	35BIOSDY
4000K	40BIOSDY	

* EML or M/P is a ratio that describes the relative melanopic lux (M) versus the photopic lux (P). BIOS provides the following m/p values: 3000K = 0.7, 3500K = 0.8, 4000K = 0.9. ** COI - Cyanosis Observation Index.

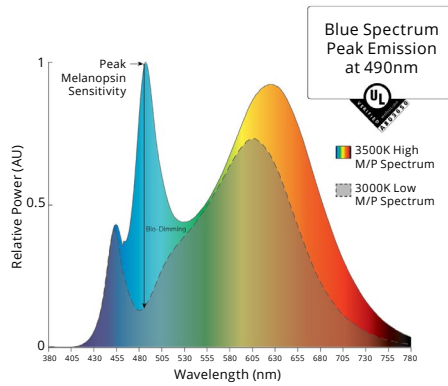

Metalumen's light level performance metrics are subject to manufacturers component tolerances.

CONTINUOUS ROWS

Step 1) Indicate desired quantity of rows under the QTY column

Step 2) ← Pods → If applicable, select pod(s) per row to indicate desired Emergency/Night Light/Battery location. If a similar row requires a different Emergency lighting location, please fill out another sheet.

Record drawings for rows not represented here will be sent out upon order.

QTY	Nominal Length	Run Length Overall	Alone / Start Length	Mid Length(s)	End Length
					ROWS IN PLAN VIEW Rows are for demonstration purposes only and are not to scale.
	4'	1225 [48.2]	4		1213 [47.8]
	8'	2442 [96.1]	8		2430 [95.7]
	12'	3661 [144.1]	12		3650 [143.7]
	16'	4881 [192.2]	8	8	2430 [95.7] 2438 [96.0]
	20'	6100 [240.2]	12	8	3650 [143.7] 2438 [96.0]
	24'	7319 [288.1]	12	12	3650 [143.7] 3658 [144.0]
	28'	8538 [336.1]	8	12	8 2430 [95.7] 3658 [144.0] 2438 [96.0]
	32'	9757 [384.1]	12	8	12 3650 [143.7] 2438 [96.0] 3658 [144.0]
	36'	10977 [432.2]	12	12	12 3650 [143.7] 3658 [144.0] 3658 [144.0]
	40'	12196 [480.2]	12	8, 8	12 3650 [143.7] 2438 [96.0] 2438 [96.0] 3658 [144.0]
	44'	13415 [528.1]	12	12, 8	12 3650 [143.7] 3658 [144.0] 2438 [96.0] 3658 [144.0]
	48'	14634 [576.1]	12	12, 12	12 3650 [143.7] 3658 [144.0] 3658 [144.0] 3658 [144.0]

LEGEND

- Standard Wire Entry Location
(located 52mm from end on top of fixture)
- Emergency (EM) / Night Light / Battery Location
- EM or Battery Wire Entry Location
(located 52mm from end on top of fixture)

Mounting Points

A **A**

A = Distance Between Mounting Points

EM / Night Light and EM or Battery Wire Entry location in relation to pod selections:

Example 20 ft run

Refer to page 5 for Hanger information

PATTERNS

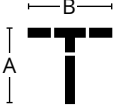
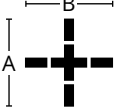
Select Pattern:	<input type="checkbox"/> T-SHAPE (C)	<input type="checkbox"/> CROSS / X-SHAPE (C)
Pattern Configuration		
Indicate Desired Lengths (ft)	A = B =	A = B =
Minimum Lengths	A = 3 ft B = 6 ft	A = 6 ft B = 6 ft

A custom pattern configuration drawing is required in the grid below

Approval drawings will be sent out upon order showing mounting locations.



HANGER

Aircraft Cable & Cord

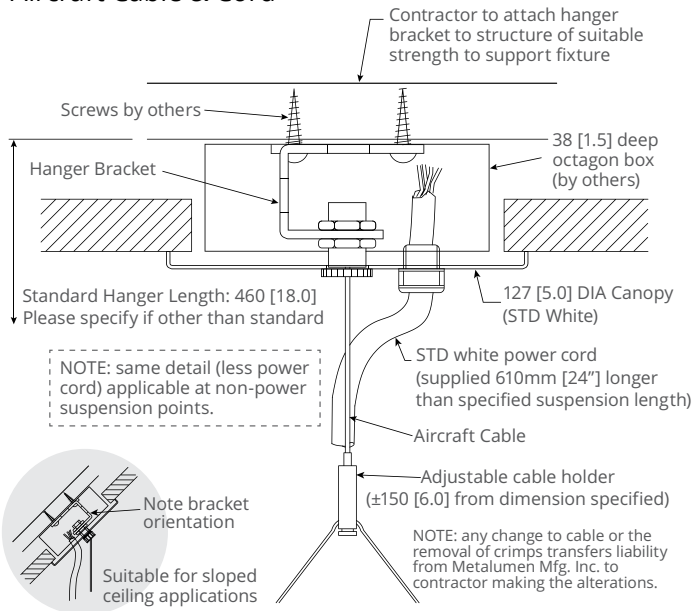

T-Bar Aircraft Cable & Cord

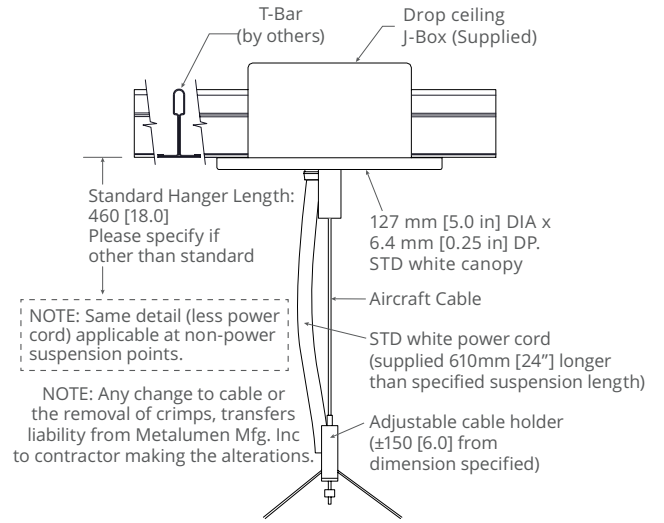

WIRING

Standard Wiring	Emergency Wiring	Emergency Battery Pack Wiring
<p>BLACK - LINE WHITE - NEUTRAL GREEN - GROUND RED - CAPPED VIOLET - DIM(+) GREY - DIM(-)</p>	<p>BLACK - LINE WHITE - NEUTRAL GREEN - GROUND RED - CAP OFF</p>	<p>BLACK - LINE WHITE - NEUTRAL GREEN - GROUND RED - UNSWITCHED HOT</p>

CROSS SECTIONS

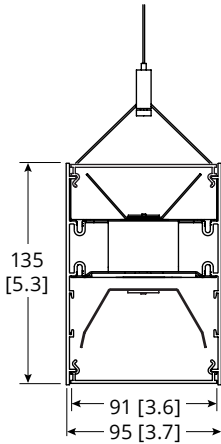

UP: Meta Blanc, DOWN: Meta Blanc
UP: Meta Ice, DOWN: Meta Ice

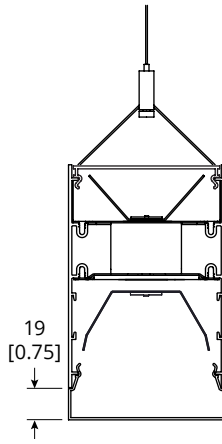

UP: Meta Blanc
DOWN: Drop Lens

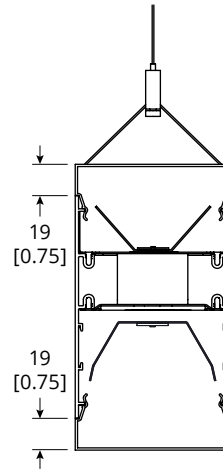

UP: Rise Lens
DOWN: Drop Lens

SPECIFICATIONS

Due to the Continuous Improvement Policy at Metalumen, we reserve the right to change our specifications without notice.

Housing: Rigid extruded aluminum body, 2.0mm (0.08”) nominal wall thickness. Aluminum end caps.

Optical System: Metalumen luminaires are designed to utilize leading edge LED technology combined with luminaire optimized reflectors and our custom diffusers, resulting in industry leading optical performance.

BIOS LED: BIOS SkyBlue® solutions have a peak wavelength at 490nm to provide an enhanced spectrum with high M/P (melanopic to photopic)

ratios while also providing a low Cyanosis Observation Index (COI), making it ideally suited for Healthcare and Healthy Lighting projects. BIOS® SkyBlue® lighting solutions also contribute to satisfying Circadian Lighting Design Feature for WELL Building Standard v1 and v2.

CRI: 83+ for 3500K, 80 minimum for all CCTs in standard configurations.

Lumen Maintenance: Minimum 50,000h with TM-21 lumen maintenance of 85% @ 25°C ambient temperature (calculated based on

IESNA LM-80-08 LED test data). L70: ≥60,000hrs.

Finish: Satin aluminum, white and black are standard finishes. For custom finish, contact factory.

Weight: 2.1 kg/300mm [4.6 lb/ft]

Mounting: Aircraft cable yoke complete with a Quick-Grip field adjustable suspension system provides for quick and easy onsite alignment.

Electrical: Factory prewired with easy wire quick connect sections.

Drivers: Metalumen offers 0-10V

dimming* as a standard on our entire LED product offering. Dimming range is 1%-100%. Power factor is > 90%. Class 2 rating. Drivers are integral.

Approvals: All components are UL/ CSA/QPS recognized or listed. RoHS compliant. cULus listed.

Environment: Suitable for dry or damp locations.

**Standard drivers compatible with passive/ sinking dimmers. Please contact Metalumen if active/sourcing dimmer support is required.*

	DLC Approved RM4DI Products	RM4DI-2L35K-4-MM-xx-L1X-X-XX-[34]-X	RM4DI-2L35K-8-MM-xx-L1X-X-XX-[34]-X	For more Metalumen DLC Approved Products, visit the DLC Website
		RM4DI-2L35K-4-MM-xx-L2X-X-XX-[34]-X	RM4DI-2L35K-8-MM-xx-L2X-X-XX-[34]-X	
		RM4DI-2L35K-4-MM-xx-L3X-X-XX-[34]-X	RM4DI-2L35K-8-MM-xx-L3X-X-XX-[34]-X	
		RM4DI-2L40K-4-MM-xx-L1X-X-XX-[34]-X	RM4DI-2L40K-8-MM-xx-L1X-X-XX-[34]-X	
		RM4DI-2L40K-4-MM-xx-L2X-X-XX-[34]-X	RM4DI-2L40K-8-MM-xx-L2X-X-XX-[34]-X	
		RM4DI-2L40K-4-MM-xx-L3X-X-XX-[34]-X	RM4DI-2L40K-8-MM-xx-L3X-X-XX-[34]-X	

WARRANTY

Metalumen will warrant defective luminaires for 5 years from date of purchase. Warranty is valid if luminaire is installed and used according to specification. If defective, Metalumen will send replacement boards or drivers at no cost along with detailed replacement instructions and instructions on how to return defective components to Metalumen.

PHOTOMETRIC DATA - 3500K, 80 CRI

Optics Up: Meta Blanc
Optics Down: Meta Blanc
IES File: RM4DI-2L35K-4-MBMB-L3
Lumens: 1274/ft Wattage: 12.1/ft
Efficacy: 106 lm/W

ZONAL LUMEN SUMMARY

Table with 3 columns: Zone, Lumens, %Fixt. Rows range from 0-20 to 0-180.

PHOTOMETRIC CURVE

51% Up
49% Down

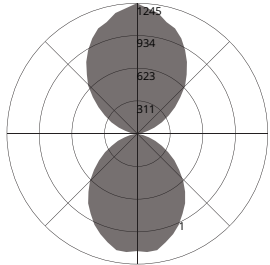

COEFFICIENTS OF UTILIZATION

Zonal Cavity Method | Effective Floor Cavity Reflectance = .20

Utilization coefficient table with columns for RC, RW, and RCR across different room dimensions.

LUMINANCE DATA (CD/M^2)

Luminance data table with columns for Vertical Angle and Horizontal Angle.

CANDELA DISTRIBUTION

Candela distribution table with columns for Vertical Angle and Horizontal Angle.

Optics Up: Meta Blanc
Optics Down: Drop Lens
IES File: RM4DI-2L35K-4-MBMD-L3
Lumens: 1290/ft Wattage: 12.1/ft
Efficacy: 107 lm/W

ZONAL LUMEN SUMMARY

Table with 3 columns: Zone, Lumens, %Fixt. Rows range from 0-20 to 0-180.

PHOTOMETRIC CURVE

54% Up
47% Down

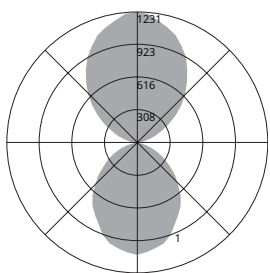

COEFFICIENTS OF UTILIZATION

Zonal Cavity Method | Effective Floor Cavity Reflectance = .20

Utilization coefficient table with columns for RC, RW, and RCR across different room dimensions.

LUMINANCE DATA (CD/M^2)

Luminance data table with columns for Vertical Angle and Horizontal Angle.

CANDELA DISTRIBUTION

Candela distribution table with columns for Vertical Angle and Horizontal Angle.

Optics Up: Rise Lens
Optics Down: Drop Lens
IES File: RM4DI-2L35K-4-MRMD-L3
Lumens: 1300/ft Wattage: 12.1/ft
Efficacy: 107 lm/W

ZONAL LUMEN SUMMARY

Table with 3 columns: Zone, Lumens, %Fixt. Rows range from 0-20 to 0-180.

PHOTOMETRIC CURVE

51% Up
49% Down

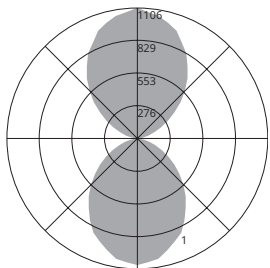

COEFFICIENTS OF UTILIZATION

Zonal Cavity Method | Effective Floor Cavity Reflectance = .20

Utilization coefficient table with columns for RC, RW, and RCR across different room dimensions.

LUMINANCE DATA (CD/M^2)

Luminance data table with columns for Vertical Angle and Horizontal Angle.

CANDELA DISTRIBUTION

Candela distribution table with columns for Vertical Angle and Horizontal Angle.

Photometric performance is measured and scaled in accordance with IESNA LM-79.

PHOTOMETRIC DATA - 3500K, 80 CRI

Optics Up: **Meta Ice**
 Optics Down: **Meta Ice**
 IES File: **RM4DI-2L35K-4-MM-L3**
 Lumens: **1352/ft** Wattage: **12.1/ft**
 Efficacy: **112 lm/W**

PHOTOMETRIC CURVE
 51% Up
 49% Down

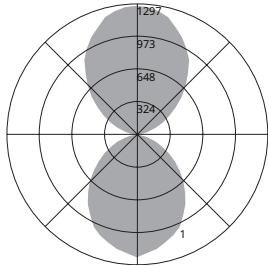

ZONAL LUMEN SUMMARY

Zone	Lumens	%Fixt
0-20	423	7.8
0-30	874	16.1
0-40	1378	25.4
0-60	2227	41.1
0-80	2595	47.9
0-90	2624	48.5
10-90	2511	46.4
20-40	955	17.6
20-50	1428	26.4
40-70	1097	20.3
60-80	368	6.8
70-80	120	2.2
80-90	29	0.5
90-110	141	2.6
90-120	402	7.4
90-130	803	14.8
90-150	1855	34.3
90-180	2792	51.5
110-180	2651	48.9
0-180	5415	100.0

COEFFICIENTS OF UTILIZATION

Zonal Cavity Method | Effective Floor Cavity Reflectance = .20

RC	80			70			50				
	RW	70	50	30	10	70	50	30	10		
RCR											
0	107	107	107	107	98	98	98	82	82	82	
1	98	94	90	87	90	87	83	80	73	71	69
2	89	82	76	71	82	76	71	67	64	61	57
3	82	73	66	60	75	67	61	56	57	53	49
4	75	65	57	51	69	60	53	48	51	46	42
5	69	58	50	44	63	54	47	41	46	40	36
6	64	52	44	38	59	48	41	36	41	36	32
7	59	47	39	34	54	44	37	32	38	32	28
8	55	43	35	30	50	40	33	28	34	29	25
9	51	39	32	27	47	36	30	25	32	26	23
10	48	36	29	24	44	34	27	23	29	24	20

CANDELA DISTRIBUTION

Vertical Angle	Horizontal Angle				
	0	22.5	45	67.5	90
0	1215	1215	1215	1215	1215
10	1150	1161	1160	1159	1134
20	1063	1053	1053	1039	1032
30	921	923	906	871	866
40	747	734	707	676	670
50	557	542	512	488	471
60	368	359	331	304	294
70	200	191	170	157	153
80	69	66	58	54	51
90	4	3	3	3	3
100	61	57	53	46	44
110	196	189	180	167	163
120	375	373	350	332	330
130	583	573	554	528	513
140	790	790	765	749	739
150	985	987	969	958	949
160	1130	1121	1116	1112	1105
170	1242	1231	1231	1251	1225
180	1276	1276	1276	1276	1276

LUMINANCE DATA (CD/M²)

Vertical Angle	Horizontal Angle		
	0	45	90
45	7113	3590	2830
55	5881	2452	1850
65	4429	1503	1098
75	2915	715	502
85	1038	152	110

Optics Up: **Batwing**
 Optics Down: **Meta Blanc**
 IES File: **RM4DI-2L35K-4-BWMB-L3**
 Lumens: **1403/ft** Wattage: **12.0/ft**
 Efficacy: **117 lm/W**

PHOTOMETRIC CURVE
 62% Up
 38% Down

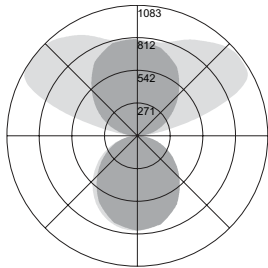

ZONAL LUMEN SUMMARY

Zone	Lumens	%Fixt
0-20	284	5.1
0-30	599	10.7
0-40	971	17.3
0-60	1678	29.9
0-80	2089	37.2
0-90	2150	38.3
10-90	2077	37
20-40	688	12.3
20-50	1063	18.9
40-70	960	17.1
60-80	412	7.3
70-80	158	2.8
80-90	61	1.1
90-110	481	8.6
90-120	1070	19.1
90-130	1709	30.4
90-150	2796	49.8
90-180	3461	61.7
110-180	2980	53.1
0-180	5612	100

COEFFICIENTS OF UTILIZATION

Zonal Cavity Method | Effective Floor Cavity Reflectance = .20

RC	80			70			50				
	RW	70	50	30	10	70	50	30	10		
RCR											
0	104	104	104	104	95	95	95	77	77	77	
1	95	91	87	83	86	82	79	76	67	65	62
2	86	79	73	68	78	72	67	62	58	55	52
3	79	69	62	56	71	63	57	52	51	47	43
4	72	61	53	47	65	56	49	44	46	41	37
5	66	54	46	40	60	50	43	37	41	36	32
6	61	49	41	35	55	45	38	32	37	31	27
7	56	44	36	31	51	40	33	28	33	28	24
8	52	40	32	27	47	36	30	25	30	25	21
9	48	36	29	24	44	33	27	22	28	22	19
10	45	33	26	21	41	30	24	20	25	20	17

CANDELA DISTRIBUTION

Vertical Angle	Horizontal Angle				
	0	22.5	45	67.5	90
0	784	784	784	784	784
10	775	775	775	776	779
20	766	765	763	763	765
30	757	755	749	743	743
40	723	728	733	717	714
50	689	694	698	686	679
60	656	659	658	651	637
70	602	614	616	613	590
80	548	559	572	567	540
90	494	505	513	511	486
100	440	450	455	453	429
110	386	396	397	393	370
120	332	343	342	331	310
130	277	288	288	264	249
140	222	233	235	200	189
150	167	178	179	140	133
160	112	123	125	89	79
170	57	68	72	52	30
180	2	13	19	19	12

LUMINANCE DATA (CD/M²)

Vertical Angle	Horizontal Angle		
	0	45	90
45	6024	6260	5926
55	5807	5972	5563
65	5658	5885	5074
75	5566	5976	4425
85	5622	7123	2935

Photometric performance is measured and scaled in accordance with IESNA LM-79.