

**NOTE:** The following instructions provide general guidelines for product installation. For additional information consult the applicable electrical codes or contact factory directly for support before attempting anything with uncertainty.

**CAUTION:** Do not assemble fixture runs on floor.

**WARNING:** Risk of fire and electrical shock. **DISCONNECT POWER AT ELECTRICAL PANEL** before installing or servicing this product.

### GENERAL SAFETY INSTRUCTIONS:

1. Read all instructions prior to installing this fixture.
2. This product must be installed in accordance with the applicable installation code by a person familiar with the construction and operation of the product and the hazards involved.
3. All wiring must be performed by a qualified electrician in accordance with national and local building and electrical codes.
4. This fixture must be suitably grounded for your protection against shock hazards and to assure proper operation.
5. Make sure that the power source conforms to the requirements of this fixture.

Specifications and design subject to change without notice.

PARTS LIST

**MAIN PARTS**

- A. Side flange assembly (2)
- B. End spacer bar (2) - maintains proper width control
- C. End flange trims (2)
- D. Safety Chain (provided by others)

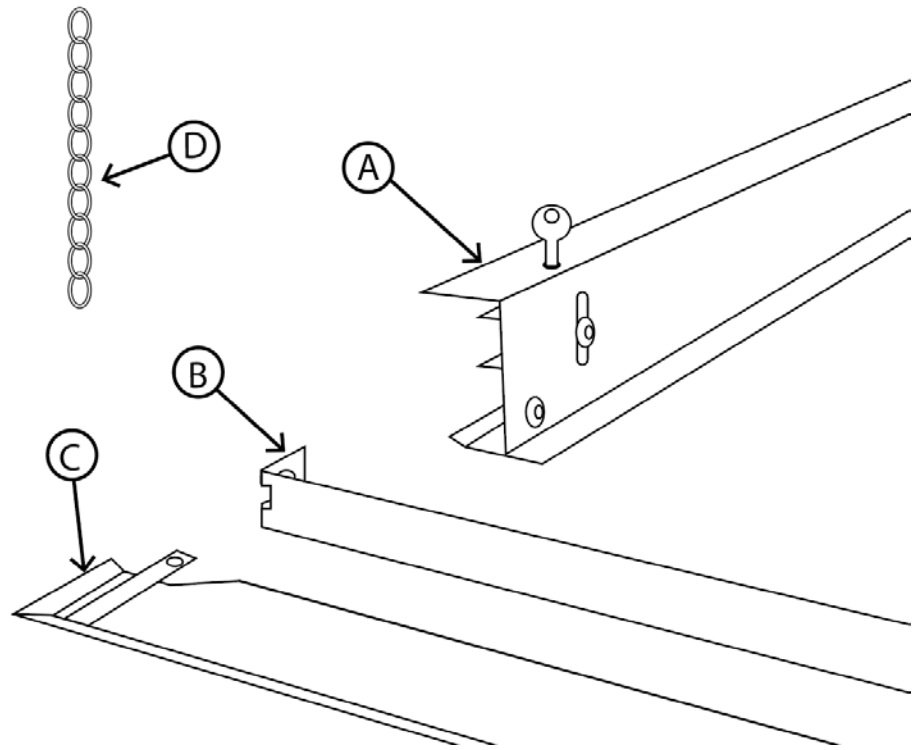

**REQUIRED TOOLS**

- Screw driver

Specifications and design subject to change without notice.

STEP-BY-STEP INSTRUCTIONS

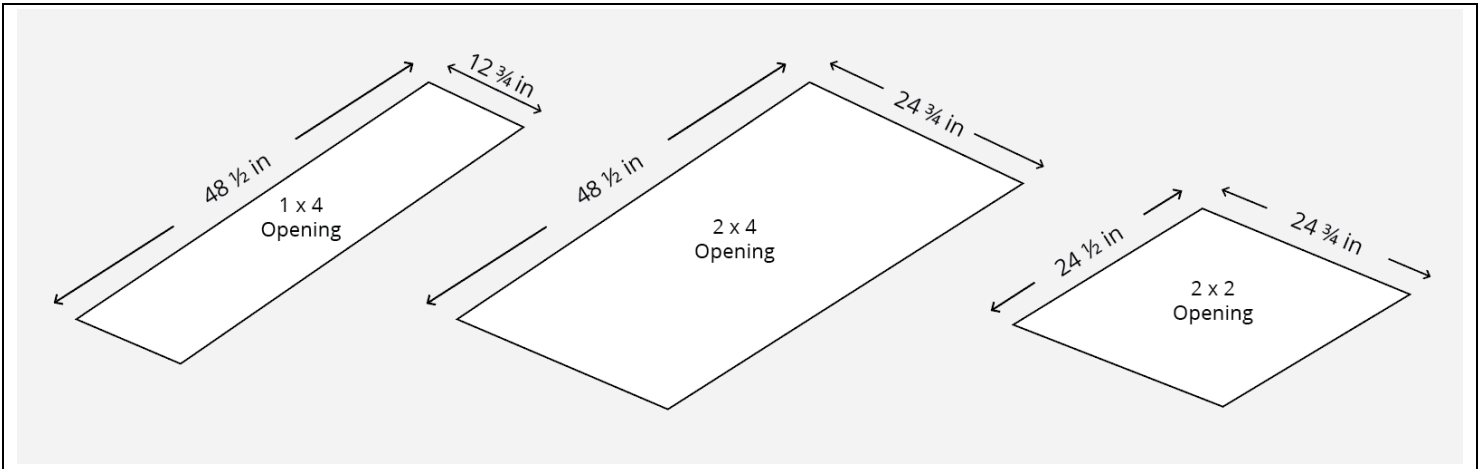

**STEP 1.** Cut opening in ceiling:

**1x4 Opening** - 48 1/2" x 12 3/4" | **2x4 Opening** - 48 1/2" x 24 3/4" | **2x2 Opening** - 24 1/2" x 24 3/4"

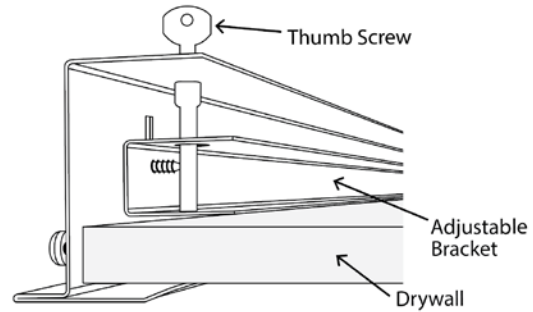
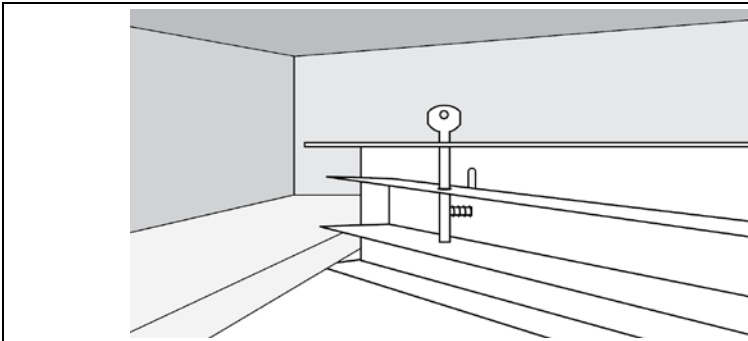

**STEP 2.** Install **side flange assembly**

**STEP 3.** Ensure the **adjustable bracket** is pressed **LIGHTLY** against drywall by gently tightening **thumb screws**, but **DO NOT** tighten all the way.

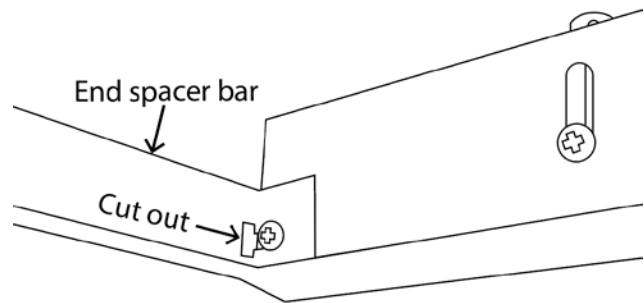

**STEP 4.** Install **end spacer bar**, but before tightening the screws, make sure all four corners are squared.

**NOTE:** Line-up rectangular cut-out slot to the head of the screw and slide in place.

Specifications and design subject to change without notice.

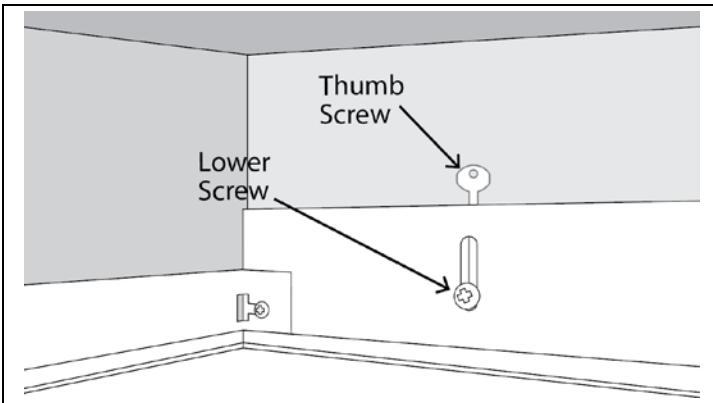

**STEP 5.** Make flange kit flush with ceiling surface by tightening the **lower screw** to the adjustable bracket. Secure in place by tightening the **thumb screw**.

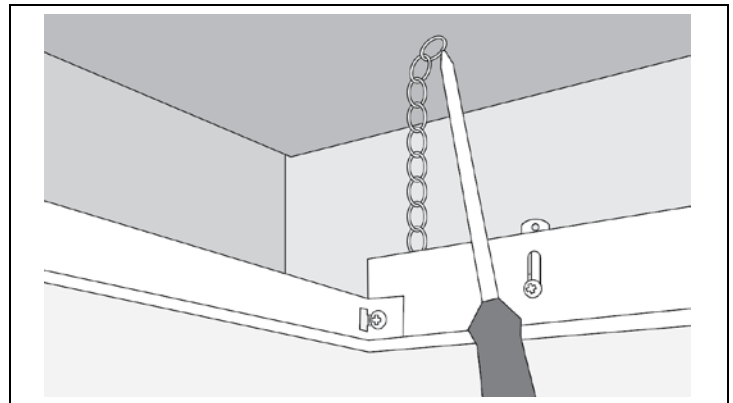

**STEP 6.** Install the **Safety Chain** (by others) from holes provided on the top of side flange assembly to the ceiling structure.

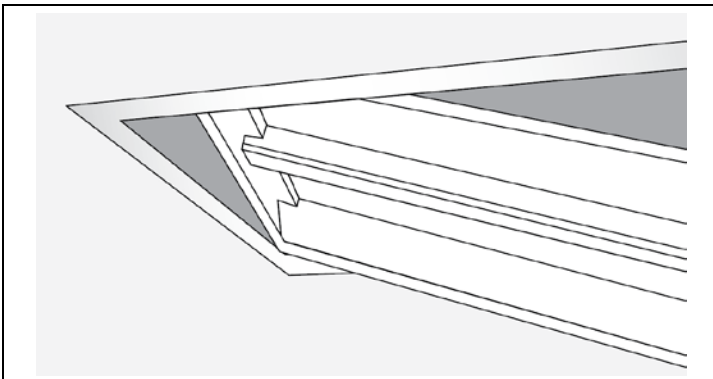

**STEP 7.** Wire fixture, then carefully lift it on an angle through the ceiling cut-out and lay it in place.  
**TIP:** For easier handling, remove door frame.

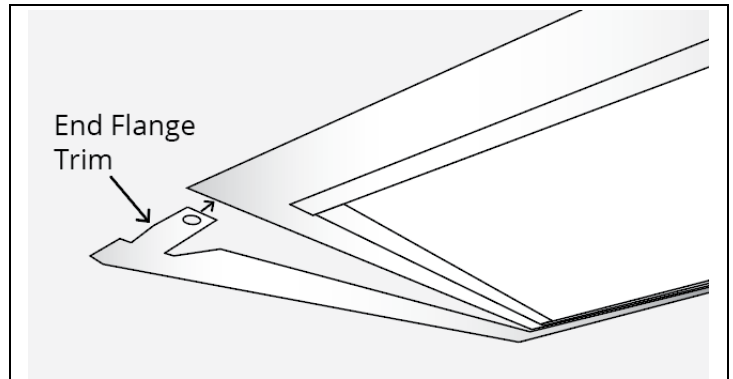

**STEP 8.** Slide in **End Flange Trim** (End flange trim is required only at the start and end of a run).

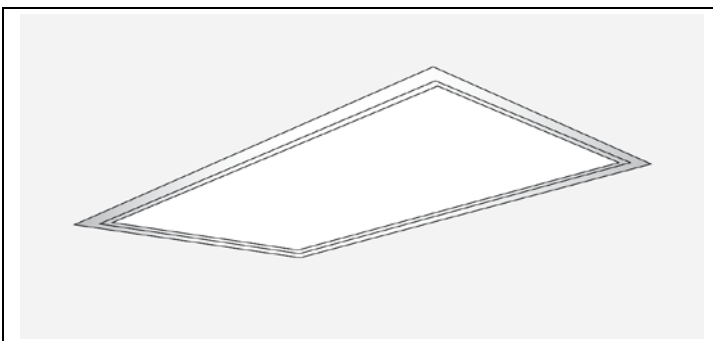

**STEP 9.** Installation is complete

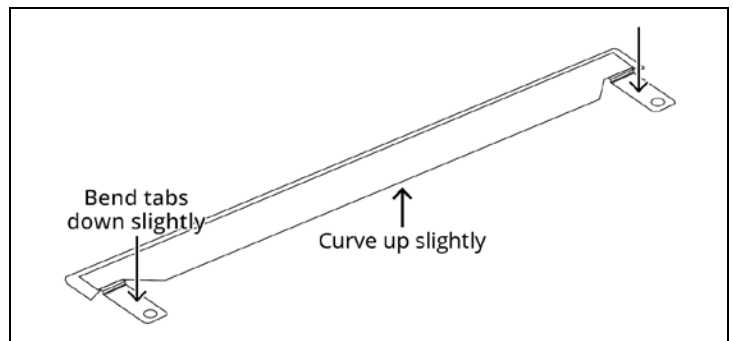

**STEP 10.** Uneven ceiling surfaces may result in some light leaks where the flange and ceiling meet. To rectify this, slightly bend the flange trims.

Specifications and design subject to change without notice.