



**NOTE:** The following instructions provide general guidelines for product installation. For additional information consult the applicable electrical codes or contact factory directly for support before attempting anything with uncertainty.

**CAUTION:** Do not assemble fixture runs on floor.

**WARNING:** Risk of fire and electrical shock. **DISCONNECT POWER AT ELECTRICAL PANEL** before installing or servicing this product.

#### **GENERAL SAFETY INSTRUCTIONS:**

1. Read all instructions prior to installing this fixture.
2. This product must be installed in accordance with the applicable installation code by a person familiar with the construction and operation of the product and the hazards involved.
3. All wiring must be performed by a qualified electrician in accordance with national and local building and electrical codes.
4. This fixture must be suitably grounded for your protection against shock hazards and to assure proper operation.
5. Make sure that the power source conforms to the requirements of this fixture.

Specifications and design subject to change without notice.

PARTS LIST

**MAIN PARTS**

- A. Luminaire Enclosure
- B. BX Junction Box
- C. Mounting Bracket

**OTHER PARTS**

- Reflector/LED Board Assembly
- Remote Driver Enclosure

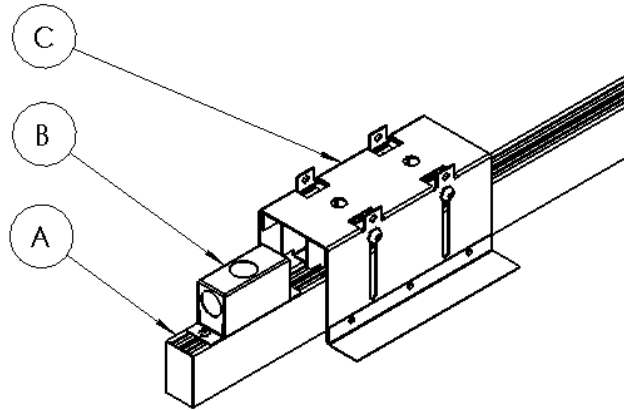

REQUIRED TOOLS

DRILL	#8 PHILLIPS BIT	#8 PHILLIPS SCREWDRIVER	WRENCH

**Important:** Use clean gloves to avoid adding oil/dirt to optics surface. Avoid scratching optics by using installation tools with soft plastic rounded edges

WIRING DIAGRAMS

STANDARD WIRING

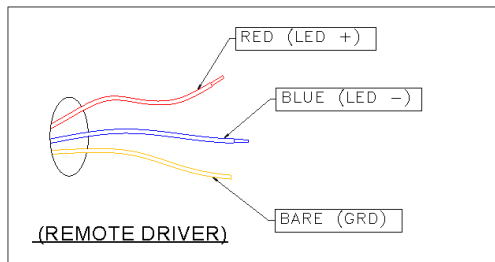

FIXTURE TO REMOTE DRIVER

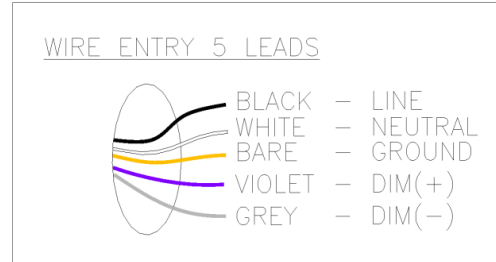

DRIVER TO LINE VOLTAGE

Specifications and design subject to change without notice.

**WITH OPTIONAL BATTERY PACK**

(6) LEADS

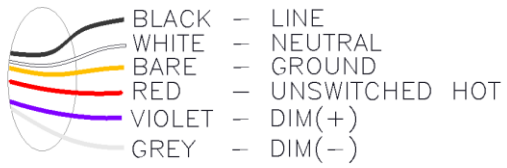

Specifications and design subject to change without notice.

STEP-BY-STEP INSTRUCTIONS

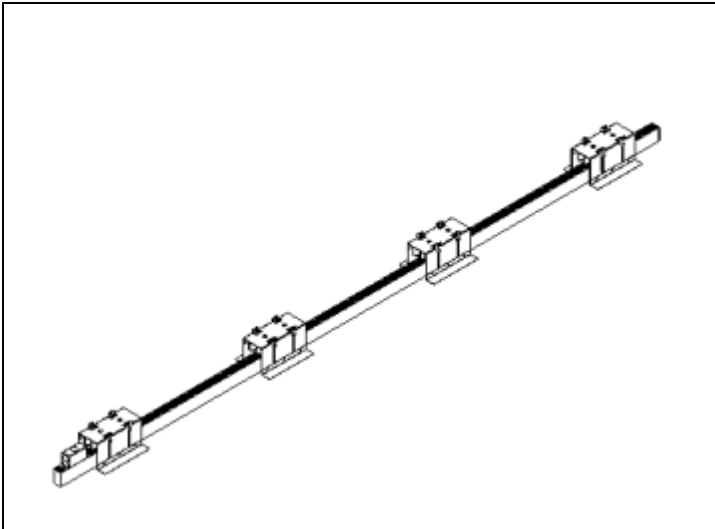

**STEP 1.** Remove fixture packaging.

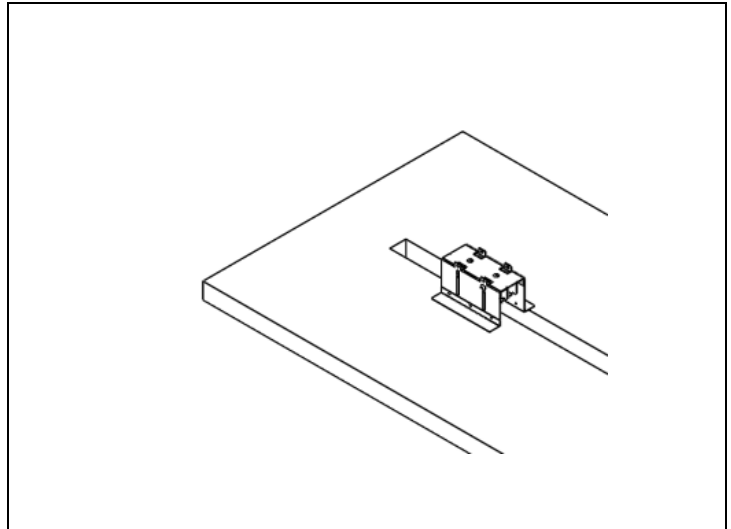

**STEP 2.** Install mounting bracket.

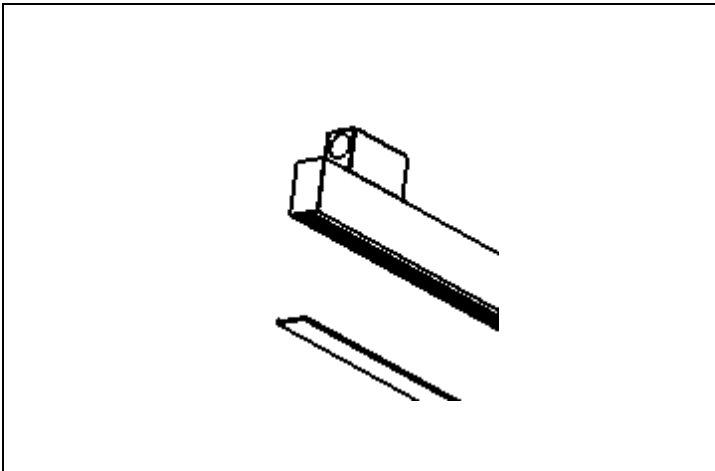

**STEP 3.** Remove lens from fixture.

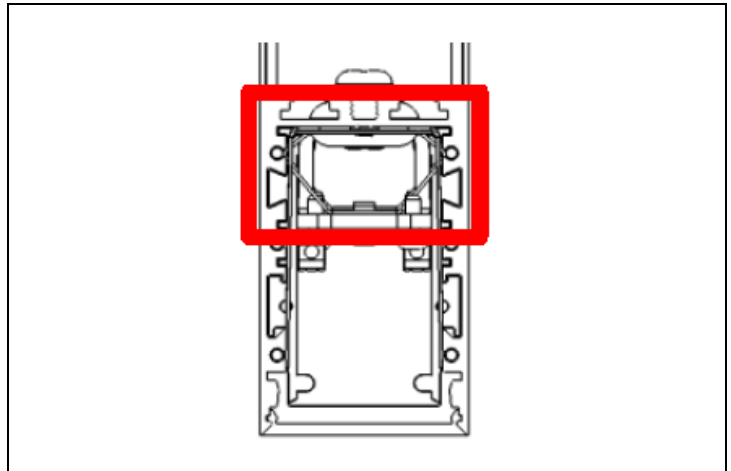

**STEP 4.** Locate the internal metal spring clips (50mm from end of LED board), depicted in above extrusion cross section. Pull up gently on the metal heat sink attached to the LED board to release these internal spring clips. Carefully remove the LED board assembly and allow it to hang freely, avoiding wire damage.

Specifications and design subject to change without notice.

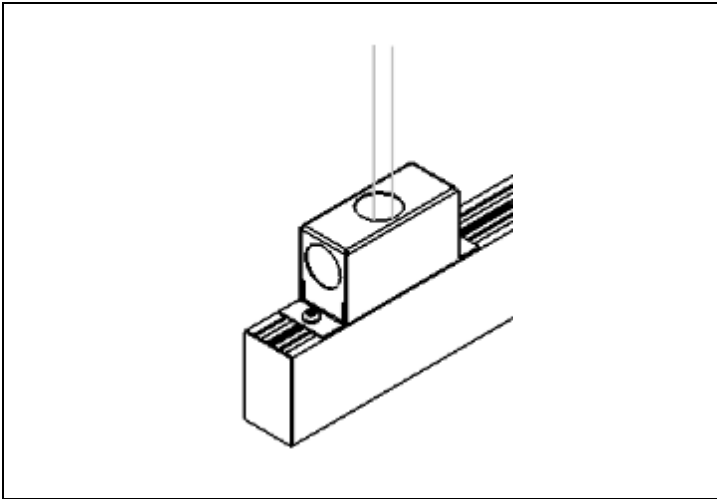

**STEP 5.** Wire remote driver box to line voltage as per wiring diagram. Ensure that the distance from the fixture to the remote driver box does not exceed 54ft unless otherwise specified.

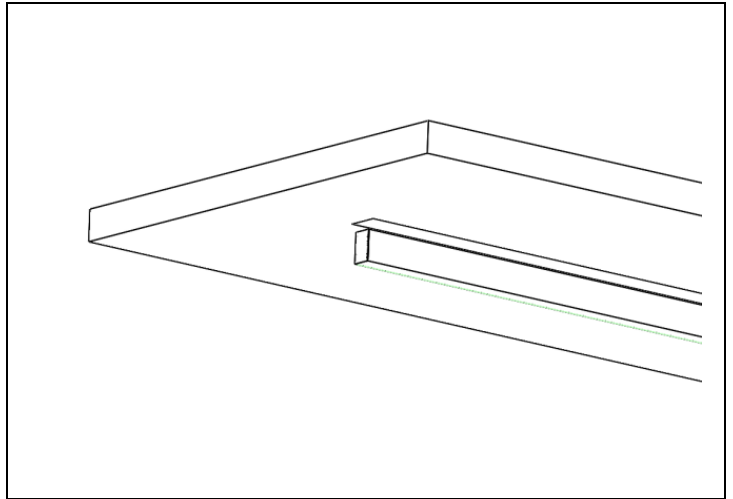

**STEP 6.** Secure the hanger canopy to the ceiling.

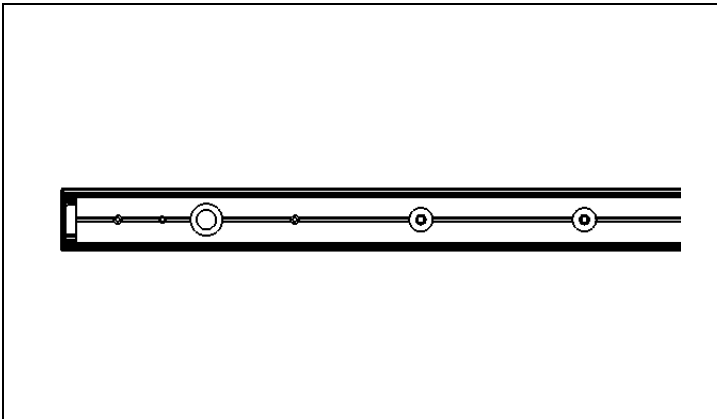

**STEP 7.** Secure fixture to mounting brackets by turning the screws attached to the spring brackets. Re-install the LED board assemblies and the lens.

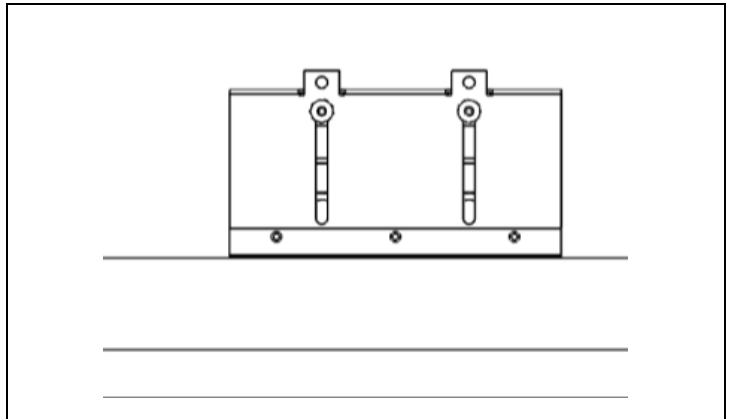

**STEP 8.** Adjust the mounting height of the fixture by loosening the 4 screws on the sides of the mounting bracket. The bottom of the fixture should be approximately flush with the drywall. Re-install the LED board assemblies and lens.

Specifications and design subject to change without notice.

JOINING INSTRUCTIONS

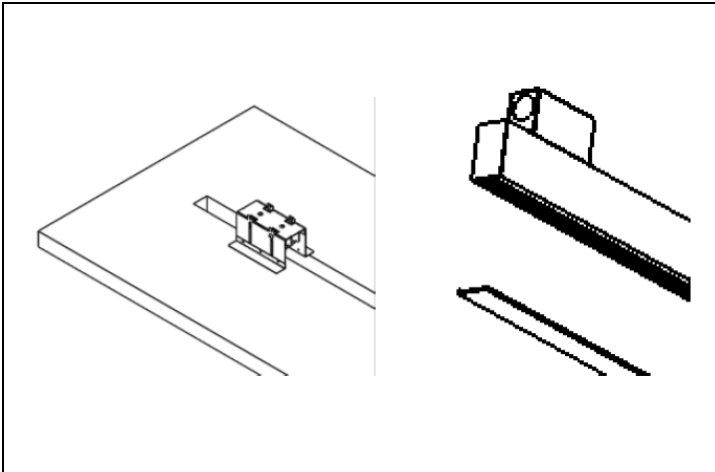

**STEP 1.** For continuous runs, install Start fixture first (as per standard installation instructions). Do not apply power. Install the mounting brackets and remove the lens from the Mid or End unit to be joined to the Start.

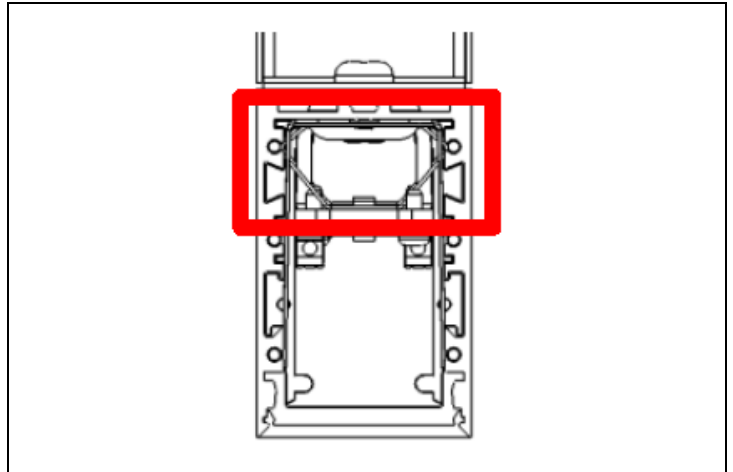

**STEP 2.** Locate the internal metal spring clips, depicted in above extrusion cross section. Pull up gently on the metal heat sink attached to the LED board to release these internal spring clips. Carefully remove the LED board assembly and allow it to hang freely, avoiding wire damage.

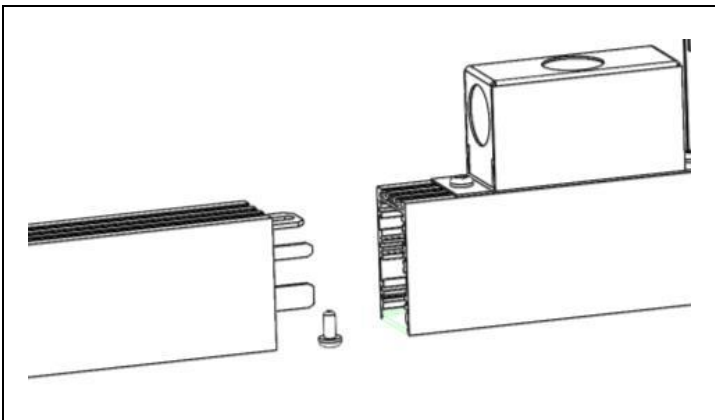

**STEP 3.** Remove the lens and LED board assembly for the Start fixture. Align the mid/end fixture to the joint and slide it into place. Secure the top bracket with the provided screw.

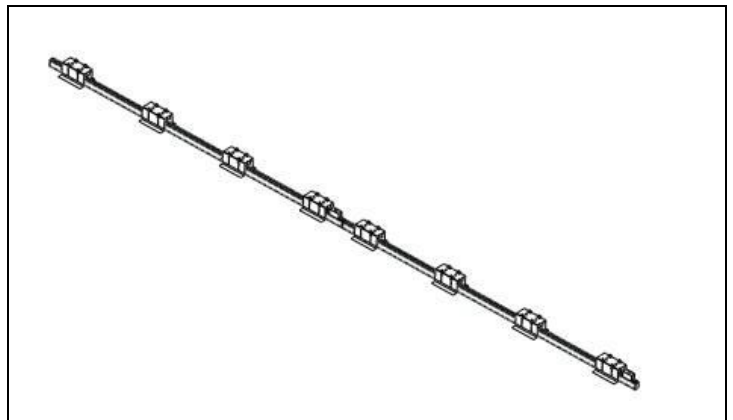

**STEP 4.** Repeat Steps 1-3 to complete the run. Perform wiring between fixtures and reinstall all parts.

Specifications and design subject to change without notice.

## MAINTENANCE

**REQUIRED TOOLS:**

- Plastic / Latex Gloves
- Screwdriver

**Important:** Use clean gloves to avoid adding oil/dirt to reflector surface. Avoid scratching reflector surface by using installation tools with soft plastic rounded edges.

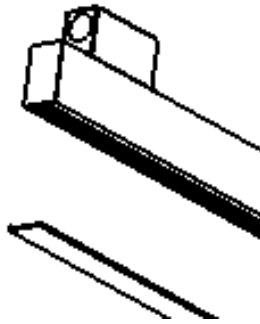

**STEP 1.** For LED board maintenance, remove the lens from the bottom of the unit. The LED boards are now accessible.

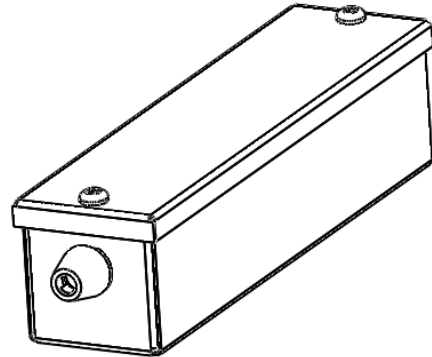

**STEP 2.** For driver maintenance, access the driver from the remote driver enclosure.

Specifications and design subject to change without notice.