



**NOTE:** The following instructions provide general guidelines for product installation. For additional information consult the applicable electrical codes or contact factory directly for support before attempting anything with uncertainty.

**CAUTION:** Do not assemble fixture runs on floor.

**WARNING:** Risk of fire and electrical shock. **DISCONNECT POWER AT ELECTRICAL PANEL** before installing or servicing this product.

### GENERAL SAFETY INSTRUCTIONS:

1. Read all instructions prior to installing this fixture.
2. This product must be installed in accordance with the applicable installation code by a person familiar with the construction and operation of the product and the hazards involved.
3. All wiring must be performed by a qualified electrician in accordance with national and local building and electrical codes.
4. This fixture must be suitably grounded for your protection against shock hazards and to assure proper operation.
5. Make sure that the power source conforms to the requirements of this fixture.

Specifications and design subject to change without notice.

PARTS LIST

**MAIN PARTS**

- A. Luminaire Enclosure
- B. Wire Entry Canopy
- C. Non-Wire Entry Canopy
- D. Aircraft Cable
- E. Power Cord
- F. Gripper

**OTHER PARTS**

- Reflector/LED board assembly
- Remote Driver Enclosure

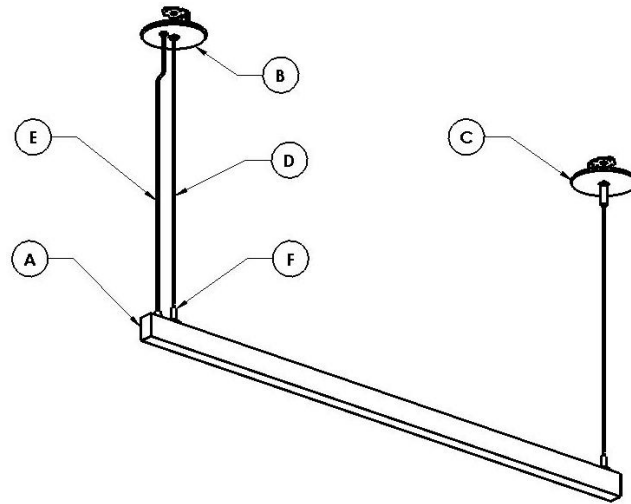

REQUIRED TOOLS

DRILL	#8 PHILLIPS BIT	#8 PHILLIPS SCREWDRIVER	WRENCH

**Important:** Use clean gloves to avoid adding oil/dirt to optics surface. Avoid scratching optics by using installation tools with soft plastic rounded edges

WIRING DIAGRAMS

STANDARD WIRING

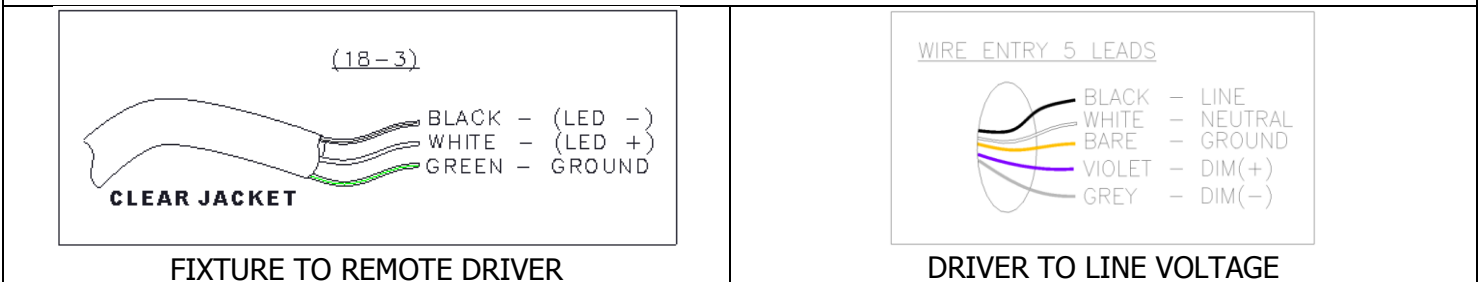

Specifications and design subject to change without notice.

**WITH OPTIONAL BATTERY PACK**

(6) LEADS

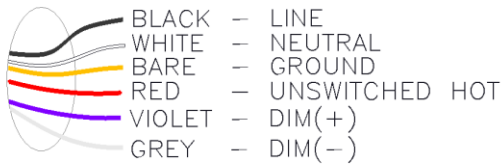

Specifications and design subject to change without notice.

STEP-BY-STEP INSTRUCTIONS

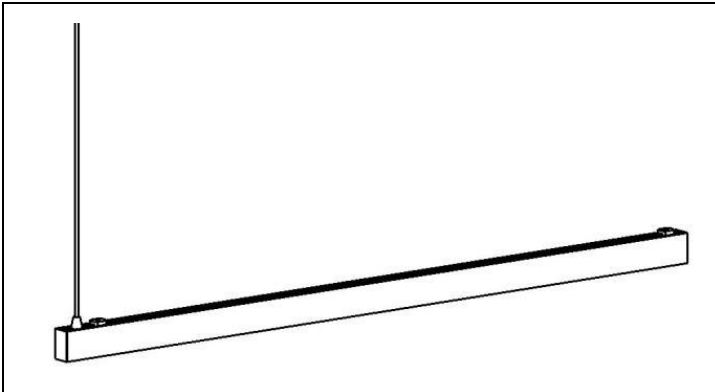

**STEP 1.** Remove fixture packaging and hanger kit packaging; note power cord position on the luminaire.

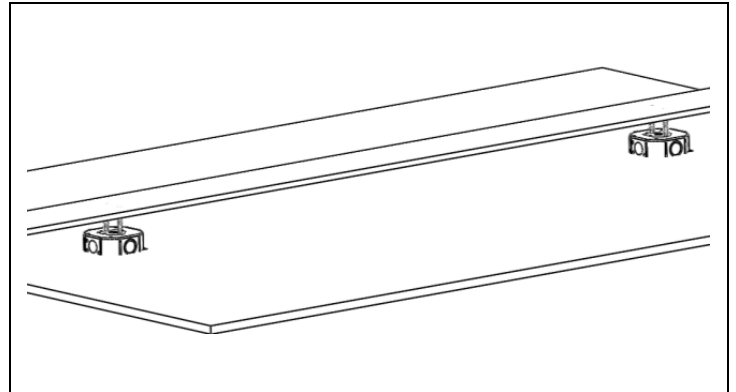

**STEP 2.** Secure Hex-Box (supplied by others) to a structure of suitable strength to support the fixture.

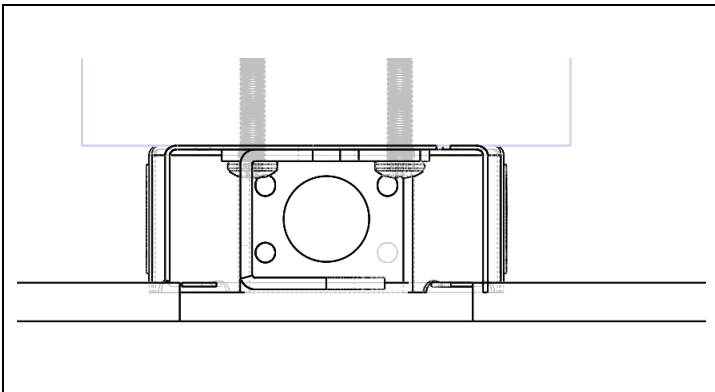

**STEP 3.** Secure hanger bracket to the hex box.

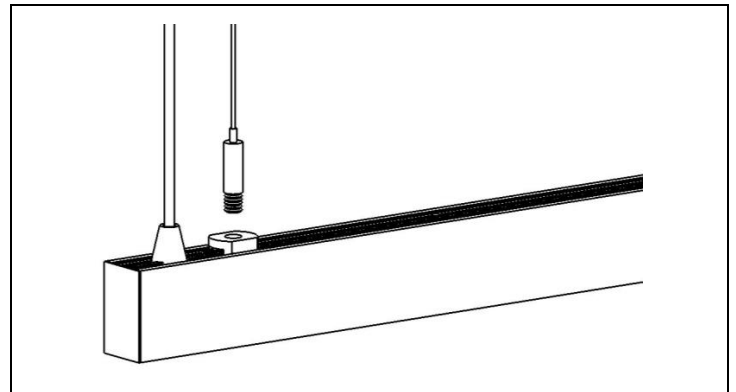

**STEP 4.** Connect gripper to fixture. Adjust height of fixture by pushing and pulling cable through gripper.

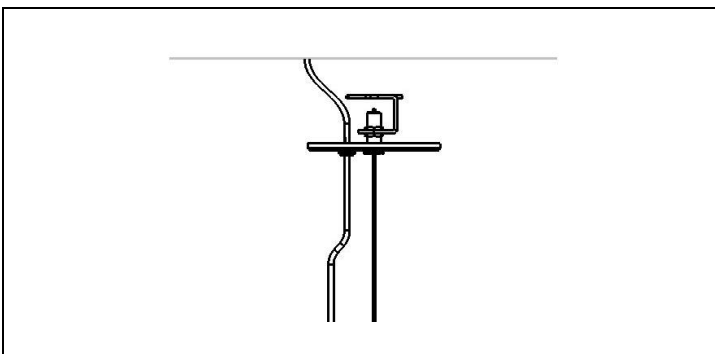

**STEP 5.** Wire remote driver box to line voltage as per wiring diagram. Ensure that the distance from the fixture to the remote driver box does not exceed 54ft unless otherwise specified.

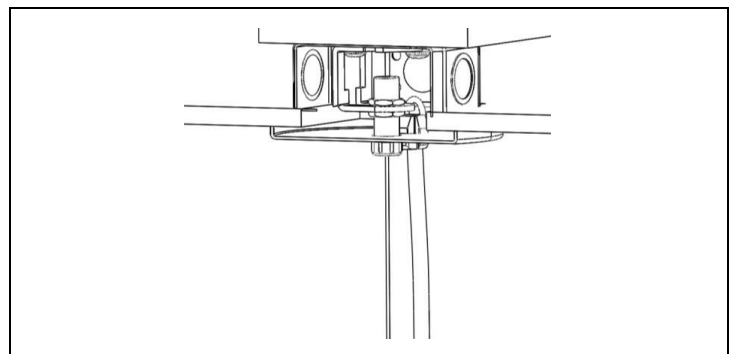

**STEP 6.** Secure the hanger canopy to the ceiling.

Specifications and design subject to change without notice.

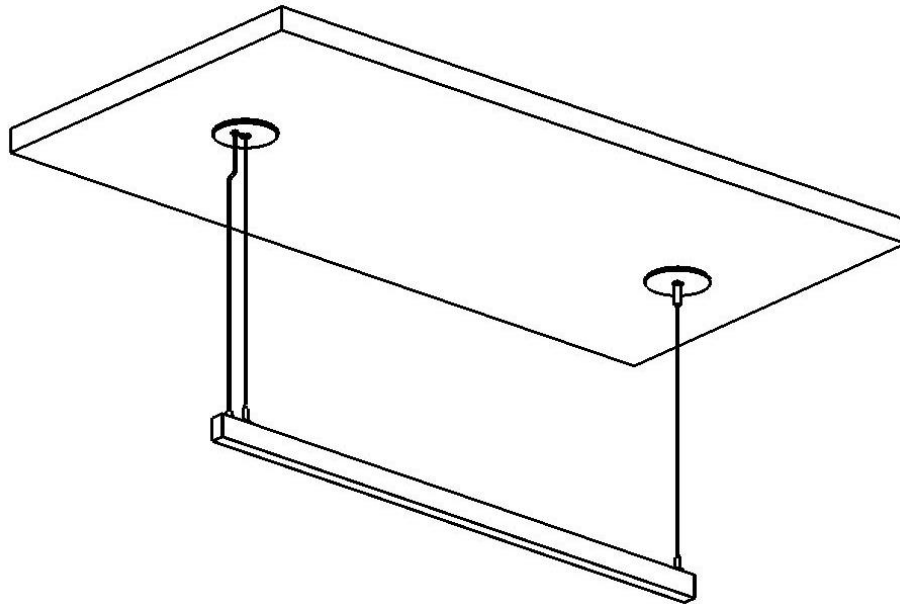

**STEP 7.** Example of completed fixture.

Specifications and design subject to change without notice.

JOINING INSTRUCTIONS

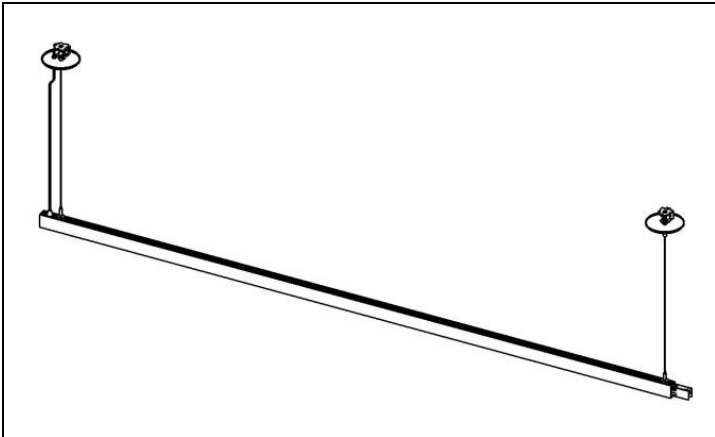

**STEP 1.** For continuous runs, install Start fixture first (as per standard installation instructions). Do not assembly runs on floor. Do not apply power.

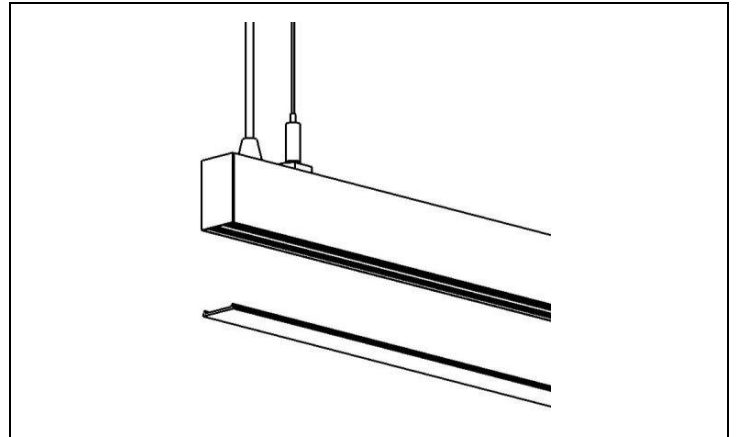

**STEP 2.** Remove the lens from the Mid or End unit to be joined to the Start.

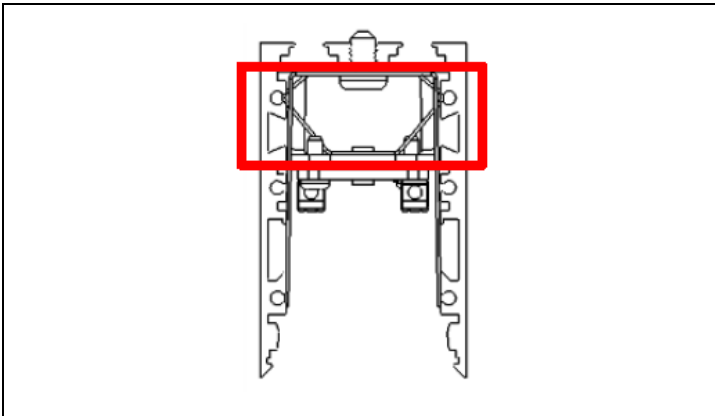

**STEP 3.** Locate the internal metal spring clips (50mm from end of LED board), depicted in above extrusion cross section. Pull up gently on the metal heat sink attached to the LED board to release these internal spring clips. Carefully remove the LED board assembly and allow it to hang freely, avoiding wire damage.

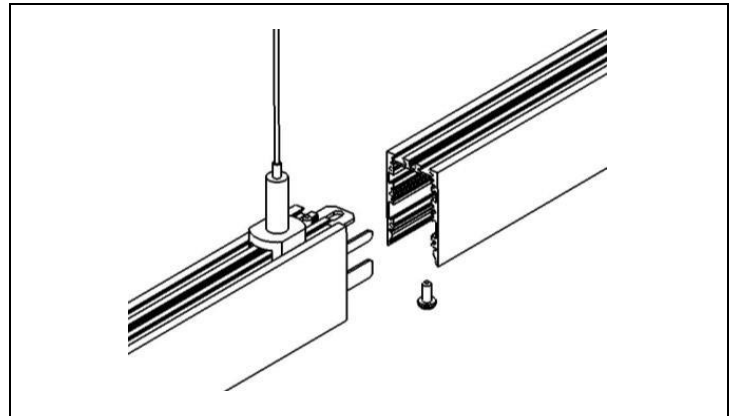

**STEP 4.** Perform Steps 2-3 for the Start fixture. Align the mid/end fixture to the joint and slide it into place. Secure the top bracket with the provided screw.

Specifications and design subject to change without notice.

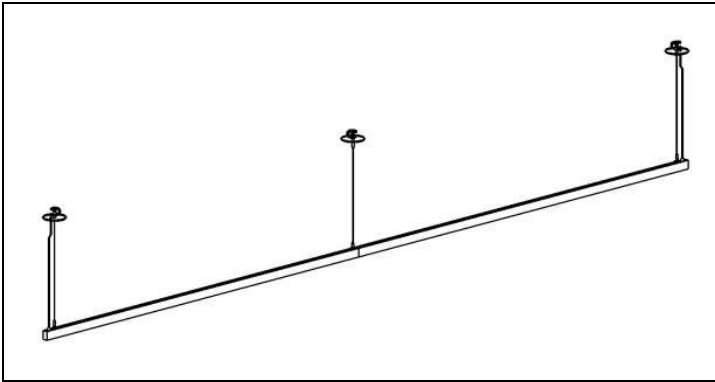

**STEP 5.** Continue to follow Steps 1-3 to complete the run, mounting hangers as necessary. Perform wiring between fixtures and reinstall all parts. Example of a completed run.

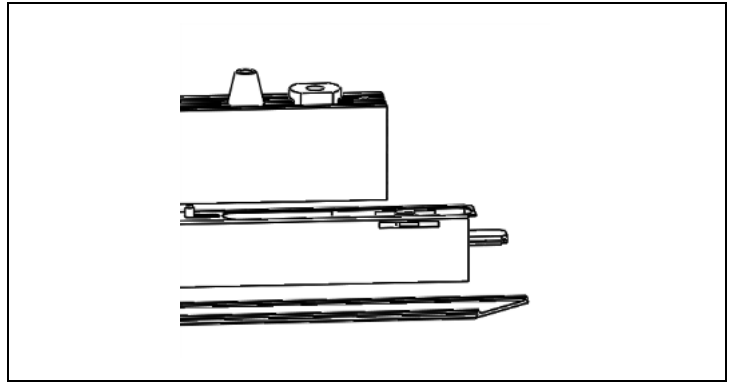

**STEP 6.** For corners, remove the lens and gently pull up on the metal heat sink attached to the LED board to release the internal spring clips (see step 3 for location of spring clip).

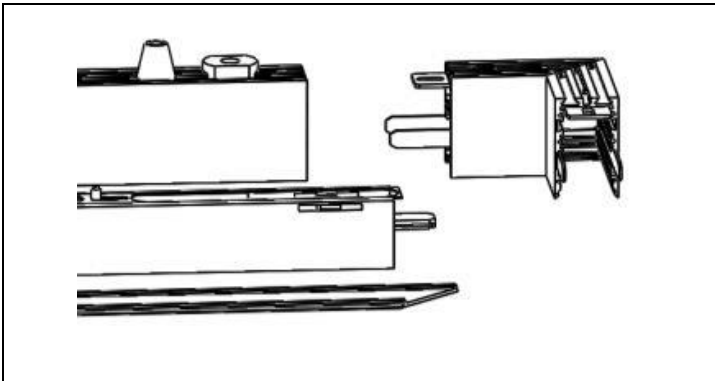

**STEP 7.** Align the corner and fixture to the joint and slide it into place. Secure the top bracket with the provided screw. Make sure there are no gaps between the corner and fixture. Repeat steps 6 and 7 for all 4 corners.

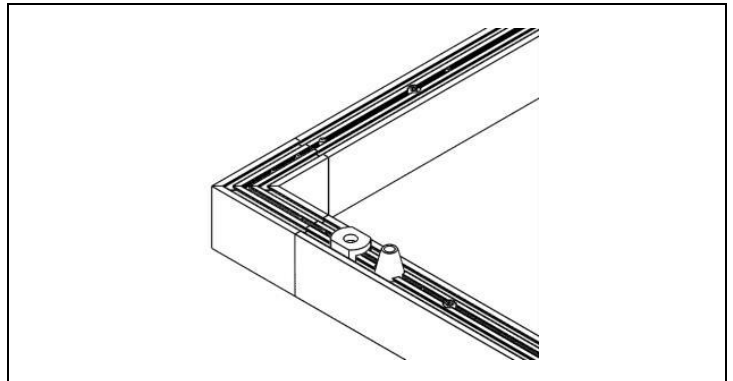

**STEP 8.** Once all the fixtures and corners are aligned, carefully reposition the LED boards and lenses into the fixture.

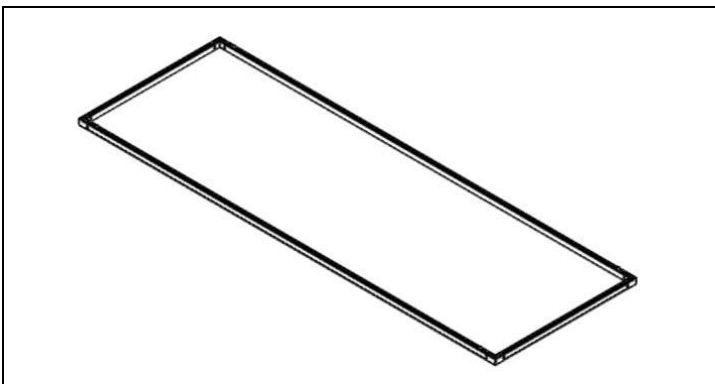

**STEP 9.** Example of a completed grid.

Specifications and design subject to change without notice.

## MAINTENANCE

**REQUIRED TOOLS:**

- Plastic / Latex Gloves
- Screwdriver

**Important:** Use clean gloves to avoid adding oil/dirt to reflector surface. Avoid scratching reflector surface by using installation tools with soft plastic rounded edges.

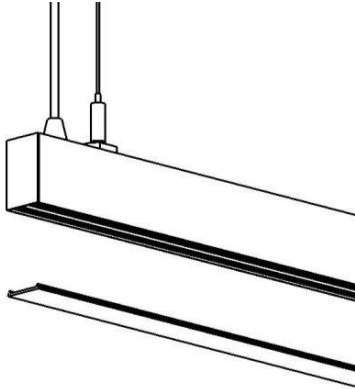

**STEP 1.** For LED board maintenance, remove the lens from the bottom of the unit. The LED boards are now accessible.

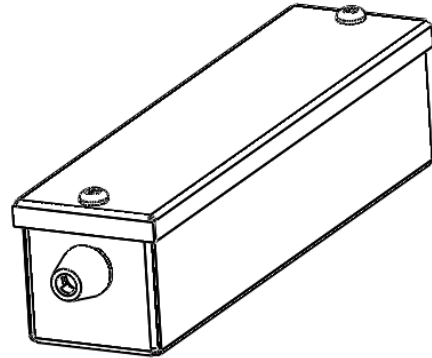

**STEP 2.** For driver maintenance, access the driver from the remote driver enclosure.

Specifications and design subject to change without notice.