

**NOTE:** The following instructions provide general guidelines for product installation. For additional information consult the applicable electrical codes or contact factory directly for support before attempting anything with uncertainty.

**CAUTION:** Do not assemble fixture runs on floor.

**WARNING:** Risk of fire and electrical shock. **DISCONNECT POWER AT ELECTRICAL PANEL** before installing or servicing this product.

### GENERAL SAFETY INSTRUCTIONS:

1. Read all instructions prior to installing this fixture.
2. This product must be installed in accordance with the applicable installation code by a person familiar with the construction and operation of the product and the hazards involved.
3. All wiring must be performed by a qualified electrician in accordance with national and local building and electrical codes.
4. This fixture must be suitably grounded for your protection against shock hazards and to assure proper operation.
5. Make sure that the power source conforms to the requirements of this fixture.

Specifications and design subject to change without notice.

PARTS LIST

**MAIN PARTS LIST**

- |                        |                   |
|------------------------|-------------------|
| A. Luminaire Enclosure | F. Aircraft Cable |
| B. Lens                | G. Canopy         |
| C. End Cap             | H. Hanger Bracket |
| D. Filler & Magnet     | I. Nut            |
| E. Cable w/Crimp       | J. AC GRIPLOK     |

**OTHER PARTS**

- Reflector
- Lamp (supplied or by others)

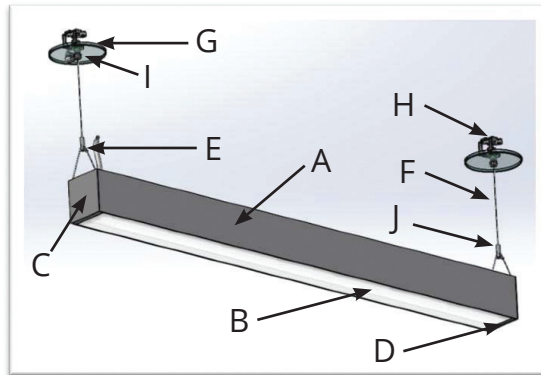

WIRING DIAGRAMS

STANDARD WIRING

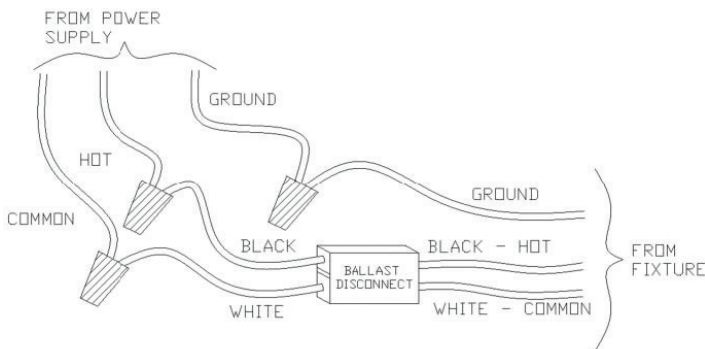

WITH OPTIONAL EMERGENCY PACK

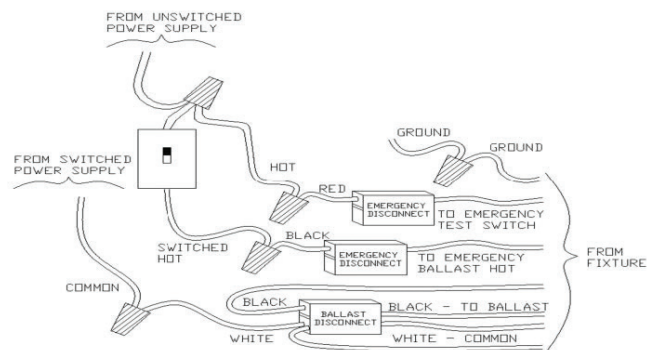

Specifications and design subject to change without notice.

STEP-BY-STEP INSTRUCTIONS

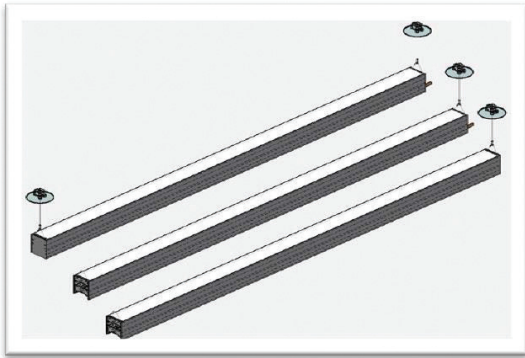

**STEP 1.** Remove fixture and hanger kit packaging.

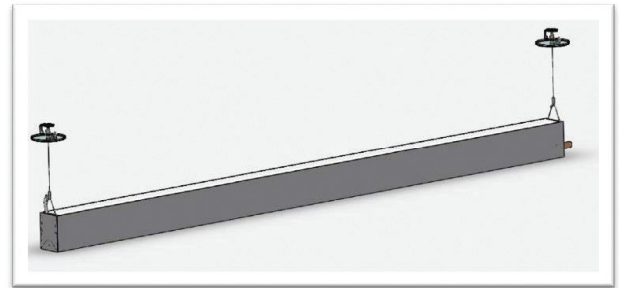

**STEP 2.** Install Start luminaire following standard installation instructions. Do not apply power to the luminaire.

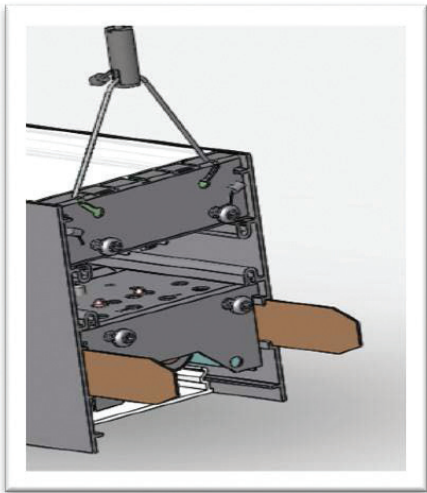

**STEP 3.** At the joiner end of the Start fixture: remove end screws (keep aligner plates inserted). Keep all parts.

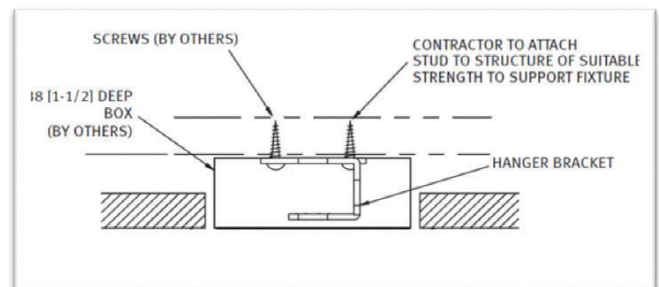

**STEP 4.** Attach hanger bracket (H) to proper mid/end fixture. One bracket needs to be attached inside electrical box.

Specifications and design subject to change without notice.

STEP-BY-STEP INSTRUCTIONS

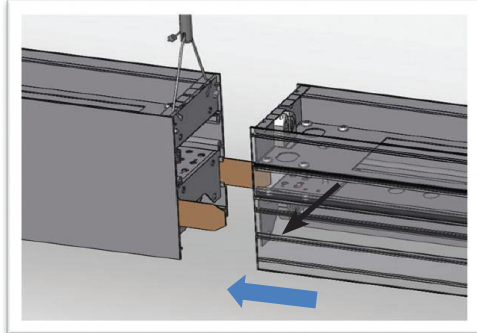

**STEP 5.** Bring Middle or End fixture with the wire end close to the Start fixture joiner end. Route wires from Start fixture through Middle/ End fixture.

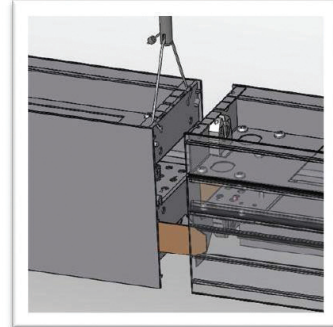

**STEP 6.** Bring fixture with the wire entry end close to the Start fixture joiner end. Attach Middle or End fixture to the Start fixture joiner end by inserting aligners from start fixture into mid/ end; placing screw thru lamp socket holes and tightening with nuts to join up fixtures.

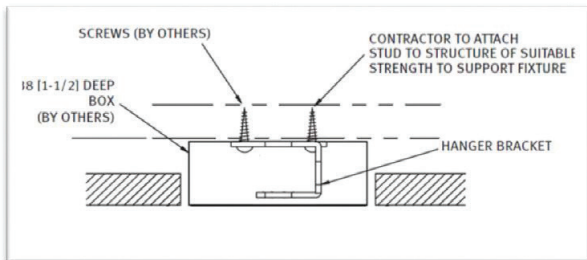

**STEP 7.** Repeat Step 4 and install Hanger bracket (1) for Mid/End Fixture. (Repeat for entire run)

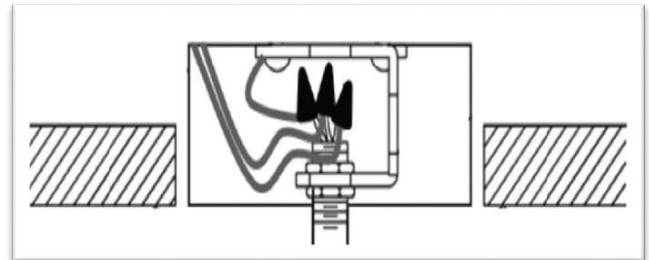

**STEP 8.** Perform electrical wiring. Optional emergency ballast must be fed from the same branch circuit as the AC ballast.

Specifications and design subject to change without notice.