

# Rail 1 RML (Formerly Caledonia)

## LED . Recessed Drywall Flangeless

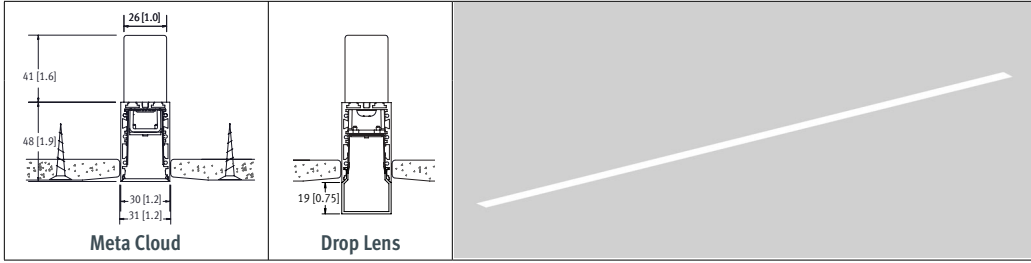

CAT #:
PREP BY:
DATE:
PROJECT:
TYPE:
NOTES:

### ORDERING LOGIC

Example Part Number: RML-1L35K-12U-MC-W-L31-DF-1-90

RML	Color Temp	Length	Pattern	Optics	Finish	LL/Driver	Circuitry	DF	Voltage	Controls	Options																				
Series	Color Temp	Length	Pattern	Up Down	Finish	LL/Driver	Circuitry	Mounting	Voltage	Controls	Options																				
1L30K = 3000K	90 CRI is available under Options	2 = 2 ft	G = Square / Rectangle	Optics Up		<b>Performance at 3500K 0-10V Dimming (Standard)</b> All drivers remote mounted		1 = 1 Circuit		= None (leave space empty)																					
1L35K = 3500K				Optics Down				B = Battery Pack (remote mounted)		Options																					
1L40K = 4000K				MC = Meta Cloud				DF = Recessed Drywall Flangeless		90 = 90 CRI																					
Color Temp		Pattern		Finish		Circuitry		Voltage		Controls																					
Length		Pattern		Finish		Circuitry		Voltage		Controls																					
3 = 3 ft	9 = 9 ft	U = U-Shape	SA = Satin Aluminum	W = White		Based on 4ft sections.		1 = 120 V		= None (leave space empty)																					
4 = 4 ft	10 = 10 ft	L = L-Shape	C = Custom Pattern*	C = Custom Finish Specify RAL#:		<table border="1"> <thead> <tr> <th colspan="4">Lumen Adjustment Factor</th> </tr> <tr> <th>Color Temp</th> <th>80 CRI</th> <th>90 CRI</th> <th></th> </tr> </thead> <tbody> <tr> <td>3000K</td> <td>0.984</td> <td>0.873</td> <td></td> </tr> <tr> <td>3500K</td> <td>1.000</td> <td>0.875</td> <td></td> </tr> <tr> <td>4000K</td> <td>1.032</td> <td>0.879</td> <td></td> </tr> </tbody> </table>		Lumen Adjustment Factor				Color Temp	80 CRI	90 CRI		3000K	0.984	0.873		3500K	1.000	0.875		4000K	1.032	0.879		2 = 277 V			
Lumen Adjustment Factor																															
Color Temp	80 CRI	90 CRI																													
3000K	0.984	0.873																													
3500K	1.000	0.875																													
4000K	1.032	0.879																													
5 = 5 ft	11 = 11 ft	C = Custom Pattern*	Enter pattern dimensions on page 2					3 = 347 V																							
6 = 6 ft	12 = 12 ft	= None (leave space empty)						4 = UNV (120 - 277 V)																							
7 = 7 ft								For other voltage, consult factory																							
R = Continuous Rows Consult factory																															
C = Custom Lengths Consult factory																															
= None (leave space empty)																															

\* Consult factory for custom patterns, including X and T patterns. | \*\* Drop lens not available with Patterns.

### SPECIFICATIONS

Due to the Continuous Improvement Policy at Metalumen, we reserve the right to change our specifications without notice.

**Housing:** Anodized Extruded Aluminum 65% post-industrial recycled content with a 20 Gauge steel die cast onboard hangers, complete with die cast zinc alloy powder coated end caps.  
**Optical System:** Computer modeled, formed painted steel materials are utilized to provide wide, horizontal direct distribution.  
**CRI:** 83 (3500K) (80 minimum)

**Lumen Maintenance:** At an ambient operating temperature of 35°C the LED lifetime expectancy =< 60 000hrs at L70.  
**Finish:** Satin Aluminum and white are standard options. For custom finish, contact factory.  
**Weight:** 1.0lb/ft or 0.5kg/300mm.  
**Mounting:** Mounting brackets/clips provided.  
**Drivers:** Metalumen offers dimming drivers

as a standard on our entire LED product offering at 0-10V. Dimming is 10%-100% range Power factor is <90% with a Class 2 rating. All drivers remote mounted.  
**Lutron Driver Options:** Consult factory for Lutron driver options:  
 • L3DAE Hi-lume 1% EcoSystem LED Driver  
 • L3DA3W Hi-lume 1% 3-wire LED Driver  
 • LTEA2W Hi-lume 1% 2-wire LED Driver  
 • LDE1 Hi-lume 1% -H EcoSystem LED Driver

• LDE5 5-Series EcoSystem LED Driver  
**Approvals:** Certified to NRTL and IES testing standards. All components are UL Recognized or Listed. RoHS compliant.  
**Environment:** Suitable for dry or damp indoor locations.

APPROVALS Signature \_\_\_\_\_

Date \_\_\_\_\_

FILE NAME: RML\_DF\_SPEC\_SHEET\_20180717

570 Southgate Drive, Guelph, Ontario N1G 4P6  
 Mailing Address: P.O. Box 1779 Guelph, Ontario, N1H 6Z9

1.800.621.6785 | T 519.822.4381 | F 519.822.4589  
 www.metalumen.com

Metalumen

**WARRANTY**

Metalumen will warrant defective luminaires for 5 years from date of purchase. Warranty is valid if luminaire is installed and used according to specification. If defective, Metalumen will send replacement boards or drivers at no cost along with detailed replacement instructions and instructions on how to return defective components to Metalumen.

**FEATURES**

 **COMMERCIAL // Commercial Lighting** - With over 30 years of successful architectural lighting, providing unique concept and installation solutions has become second nature. Metalumen's Start to End Development Process results in unique performance, design and architectural requirements from concept through implementation. Metalumen's Lighting Solutions have been applied to customer projects requiring: high

profile architectural installations; improved energy efficiency; retrofit installations; unique installations. Metalumen can provide top-quality innovative fixtures when and where they are needed and, at the same time, allow the customer to determine their level of involvement in Metalumen's Start to End Development Process.

 **EDULUMEN // Educational Lighting** - Edulumen is a

collection of premium luminaires that maximize both the functionality and performance of any educational facility. Based on maximum efficiency, integration of controls and exceptional design, Edulumen will earn high marks for meeting your requirements. Students challenge themselves throughout the day to achieve, and Metalumen is dedicated to this by creating sustainable environments that foster enhanced educational experiences.

 **MEDILUMEN // Healthcare Lighting** Every product in our broad line of healthcare luminaires has been strategically engineered to meet modern healthcare demands while addressing patient needs and aesthetic requirements.

 **DAMP** Suitable for dry or damp locations.

**PATTERNS**

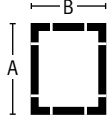
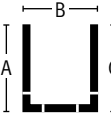
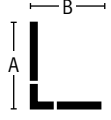
Select Pattern	Square (G)	Rectangle (G)	U-Shape (U)	L-Shape (L)
Pattern Configuration				
Indicate Desired Lengths (ft)	A =	A = B =	A =      B = C =	A = B =
Minimum Lengths	4' for all sides		A = 3', B = 4', C = 3'	A = 3', B = 3'

Record drawings will be sent out upon order showing mounting locations.

**PHOTOMETRIC DATA - 3500K**

**Meta Cloud**

File Name: RML-1L35K-4-MC-L3  
 Luminaire Lumens: 2108  
 Total Watts: 24.2  
 Efficacy: 87 lms/W

**COEFFICIENTS OF UTILIZATION**

Zonal Cavity Method | Effective Floor Cavity Reflectance = .20

RC	80			70			50			
	RW	70	50	30	10	70	50	30	10	
RCR										
0	119	119	119	119	116	116	116	111	111	111
1	110	106	102	99	108	104	100	97	100	97
2	101	94	88	83	99	92	87	82	89	84
3	93	84	76	71	91	82	75	70	79	74
4	86	75	67	61	84	74	66	61	71	65
5	80	68	60	54	78	67	59	53	65	58
6	74	62	53	47	72	61	53	47	59	52
7	69	56	48	42	67	56	48	42	54	47
8	65	52	44	38	63	51	44	38	50	43
9	60	48	40	35	59	47	40	35	46	39
10	57	44	37	32	56	44	37	32	43	36

**PHOTOMETRIC CURVE**

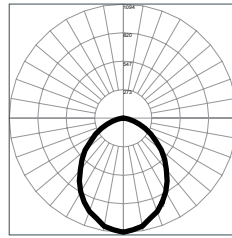

**LUMINANCE DATA (CD/M²)**

Vertical Angle	Horizontal Angle		
	0	45	90
45	20944	8413	6170
55	17284	5707	3942
65	13923	3400	2161
75	9716	1538	930
85	4415	251	142

**CANDELA DISTRIBUTION**

Vertical Angle	Horizontal Angle				
	0	22.5	45	67.5	90
0	1093.56	1093.56	1093.56	1093.56	1093.56
5	1073.75	1072.5	1053.04	1048.58	1073.76
10	1052.87	1051.05	1030.63	1016.15	1012
15	992.33	991.9	985.01	955.83	937.07
20	950.71	929.92	893.99	868.22	870.58
25	886.96	859.88	822.78	782.09	764.22
30	814.97	784.78	740.08	692.76	673.11
35	735.91	700.05	645.9	594.7	583.57
40	640.54	619.64	553.2	506.18	496.77
45	560.26	530.37	469.9	430.17	415.27
50	476.81	444.78	389.8	353.3	335.93
55	381.23	362.17	318.26	283.23	272.11
60	306.71	282.55	247.82	219.4	209.51
65	232.4	214.21	183.6	158.25	148.41
70	163.26	151.24	128.01	108.46	104.24
75	105.13	95.36	77.79	64.86	61.6
80	54.75	49.36	37.19	32.11	29.44
85	20.4	17.14	11.47	8.87	8.77
90	4.44	2.24	1.03	.88	.85

**ZONAL LUMEN SUMMARY**

Zone	Lumens	%Fixt
0-20	374.28	17.70
0-30	752.82	35.60
0-40	1159.79	54.90
0-60	1819.67	86.10
0-80	2093.88	99.10
<b>0-90</b>	<b>2112.37</b>	<b>100.00</b>
10-90	2011.67	95.20
20-40	785.52	37.20
20-50	1155.79	54.70
40-70	846.76	40.10
60-80	274.21	13.00
70-80	87.33	4.10
80-90	18.49	0.90
90-110	0.00	0.00
90-120	0.00	0.00
90-130	0.00	0.00
90-150	0.00	0.00
<b>90-180</b>	<b>0.00</b>	<b>0.00</b>
110-180	0.00	0.00
0-180	2112.37	100.00

**Drop Lens**

File Name: RML-1L35K-4-MD-L3  
 Luminaire Lumens: 2235  
 Total Watts: 24.2  
 Efficacy: 93 lms/W

**COEFFICIENTS OF UTILIZATION**

Zonal Cavity Method | Effective Floor Cavity Reflectance = .20

RC	80			70			50			
	RW	70	50	30	10	70	50	30	10	
RCR										
0	117	117	117	117	113	113	113	105	105	105
1	106	101	96	92	102	97	93	90	91	88
2	96	88	81	75	93	85	79	73	80	75
3	88	77	69	63	84	75	67	61	70	64
4	81	69	60	53	77	67	59	52	63	56
5	74	62	53	46	71	60	52	45	57	49
6	69	56	47	41	66	54	46	40	51	44
7	64	51	42	36	61	49	41	35	47	40
8	59	46	38	32	57	45	37	32	43	36
9	56	43	34	29	54	42	34	29	40	33
10	52	39	32	26	50	38	31	26	37	30

**PHOTOMETRIC CURVE**

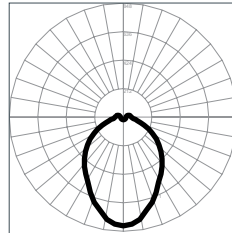

**LUMINANCE DATA (CD/M²)**

Vertical Angle	Horizontal Angle		
	0	45	90
45	15096	6174	5141
55	12506	4546	3847
65	9742	3220	2819
75	6845	2134	1936
85	4256	1383	1350

**CANDELA DISTRIBUTION**

Vertical Angle	Horizontal Angle				
	0	22.5	45	67.5	90
0	827.1	827.1	827.1	827.1	827.1
5	848.29	844.47	838.02	837.63	817.63
10	825.7	811.29	810.61	800.87	786.88
15	782.12	776.86	757.59	743.58	729.38
20	738.66	729.83	707.99	692.13	683.53
25	682.12	672.5	647.44	634.04	622.89
30	624.2	616.07	593.83	574.77	564.57
35	560.56	548.21	528.7	523.74	522.08
40	488.87	481.83	473.17	475.33	480.6
45	418.47	418.41	419.74	436.16	436.57
50	352.75	360.14	372.83	386.38	392.56
55	281.42	298.89	328.42	343.55	346.1
60	225.15	246.8	276.47	296.07	304.21
65	169.58	198.36	228.71	249.97	257.48
70	123.09	151.81	189.32	210.77	217.96
75	76.32	111.38	149.04	172.12	174.22
80	45.49	76.52	120.14	137.96	144.32
85	20.28	52.13	93.88	110.61	115.02
90	7.58	39.02	76.89	92.84	100.16

**ZONAL LUMEN SUMMARY**

Zone	Lumens	%Fixt
0-20	292.69	13.10
0-30	593.26	26.50
0-40	928.92	41.50
0-60	1545.49	69.00
0-80	1917.31	85.60
<b>0-90</b>	<b>2008.69</b>	<b>89.70</b>
10-90	1929.92	86.20
20-40	636.23	28.40
20-50	964.99	43.10
40-70	838.69	37.50
60-80	371.82	16.60
70-80	149.70	6.70
80-90	91.38	4.10
90-110	115.58	5.20
90-120	157.49	7.00
90-130	189.12	8.40
90-150	222.82	10.00
<b>90-180</b>	<b>230.09</b>	<b>10.30</b>
110-180	114.51	5.10
0-180	2238.78	100.00