

IS-S6-S rev.01
**S6 SERIES SURFACE MOUNT
DIRECT INTEGRAL DRIVER
INSTALLATION INSTRUCTIONS**

NOTE

The following instructions provide general guidelines for product installation. These instructions apply to the S6 sized fixtures. For additional information consult the applicable electrical codes or contact factory directly for support before attempting anything with uncertainty.

WARNING

Risk of fire and electrical shock. **DISCONNECT POWER AT ELECTRICAL PANEL** before installing or servicing this product.

GENERAL SAFETY INSTRUCTIONS

- Read all instructions prior to installing this fixture.
- This product must be installed in accordance with the applicable installation code by a person familiar with the construction and operation of the product and the hazards involved.
- All wiring must be performed by a qualified electrician in accordance with national and local building and electrical codes.
- This fixture must be suitably grounded for your protection against shock hazards and to assure proper operation.
- Make sure that the power source conforms to the requirements of this fixture.
- This product has accessible output terminals. Based on Canadian Electrical Code for class 2 circuits, this product requires installation in Restricted Access Area, so that no live parts are accessible to unauthorized persons.

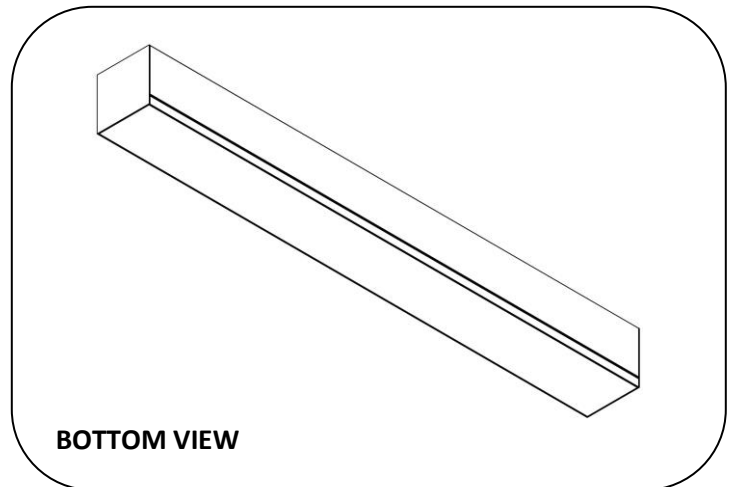
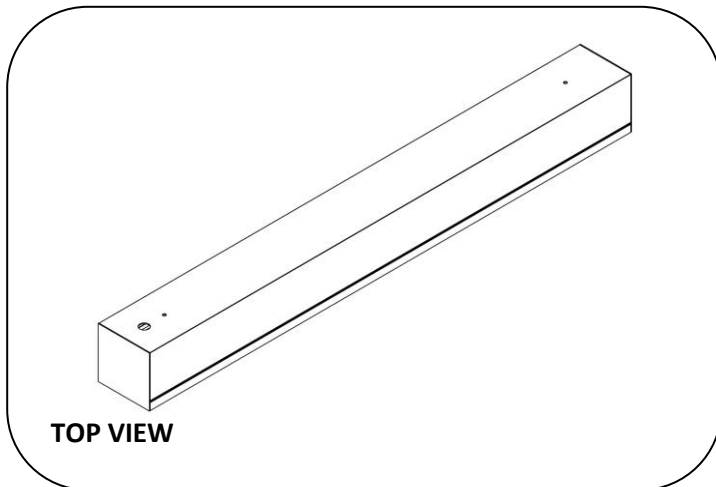

WIRING DIAGRAM

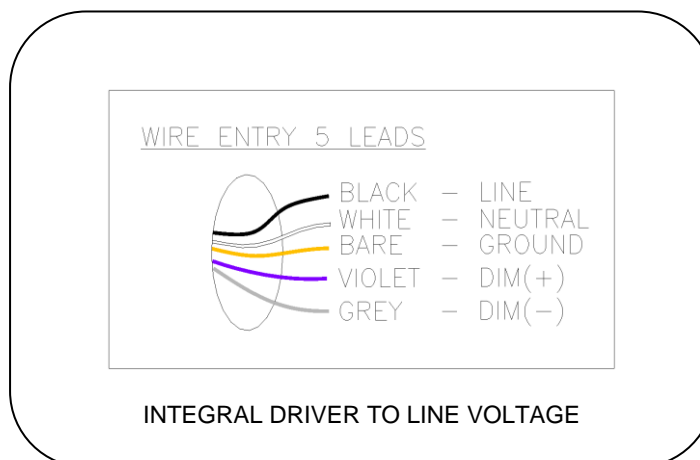

INSTALLATION STEPS

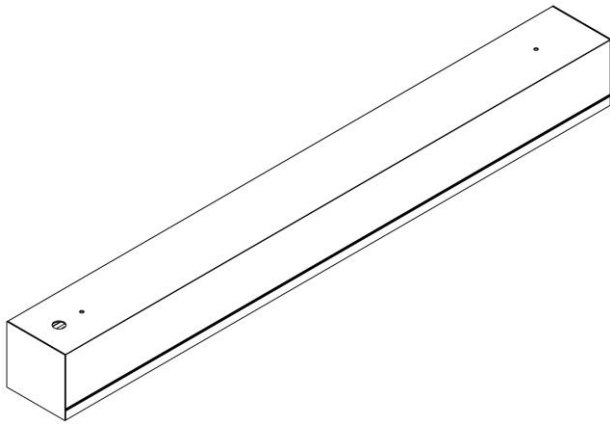

Step 1: Remove fixture packaging.

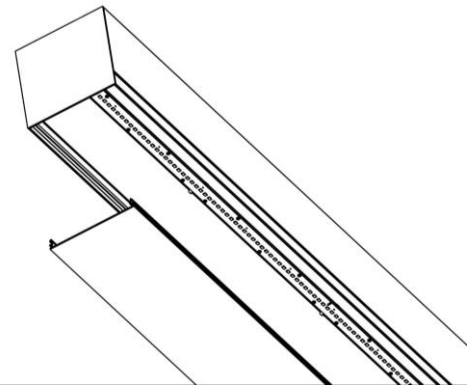

Step 2: Remove the lens from the unit.

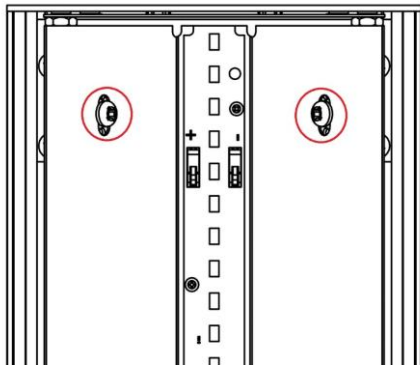

Step 3: Unscrew the reflector assembly.

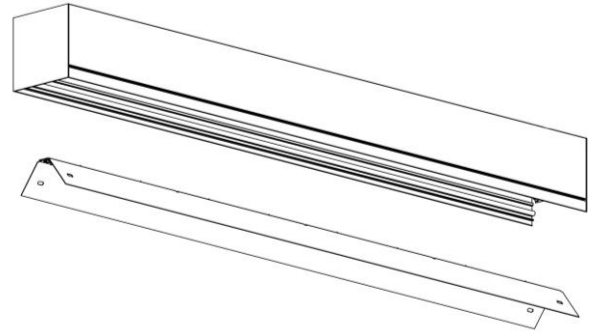

Step 4: Remove reflector assembly.

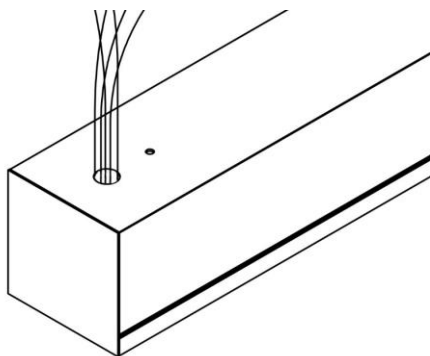

Step 5: Run wires through junction box and out through the hole in the top of the fixture.
For a grid, feed wires through the hole in the provided wire entry corner piece.



Step 6: Attach fixture to ceiling using screws (supplied by others) through the holes in the extrusion. Ensure the fixture is secured to a sufficiently strong structure. Reinstall reflector assembly and lens.

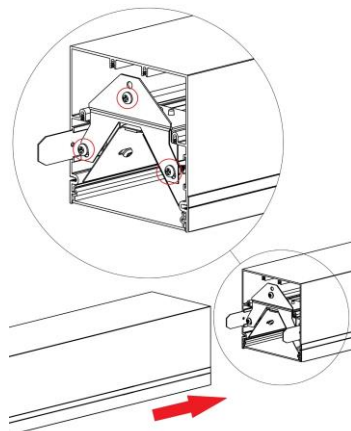

Step 7: For continuous runs, remove the lens and reflector from the mid/end unit (see steps 2-4). Attach the joiner brackets of each unit using 3 screws. Connect wires between fixtures as per the wiring diagram. Reinstall the reflector and lens in mid/end.

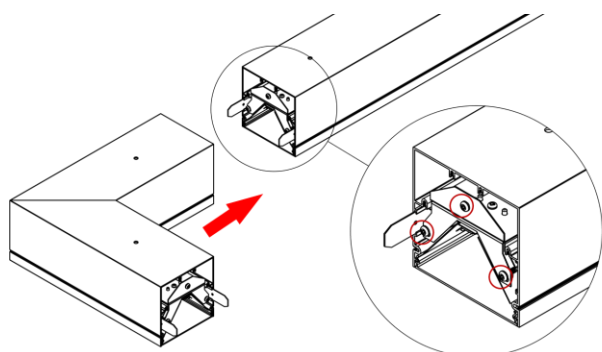

Step 8: For corners, remove the lens and reflector pairs from the corner unit (see steps 2-4). Attach the corner to the preceding unit joiner brackets using 3 screws.

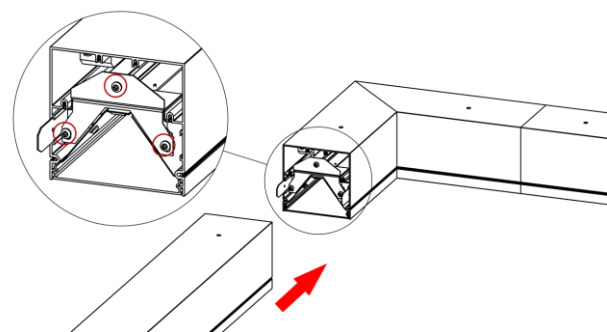

Step 9: Attach the next mid/end unit to the corner unit as per step 7. Connect wires between fixtures as per the wiring diagram. Reinstall the reflector and lens in corner.

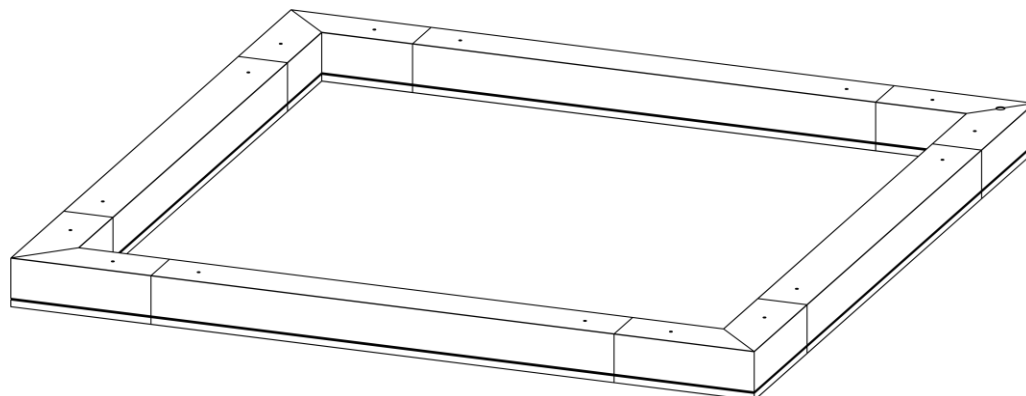

Step 10: Example of completed grid.

MAINTENANCE STEPS

Required Tools:



PLASTIC / LATEX GLOVES



SCREWDRIVER

Important: Use clean gloves to avoid adding oil/dirt to reflector surface. Avoid scratching reflector surface by using installation tools with soft plastic rounded edges.

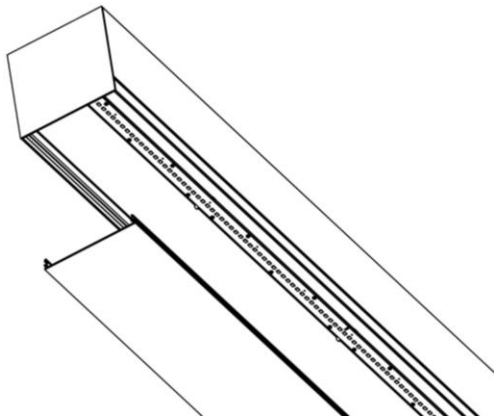

Step 1: For LED board maintenance, remove the lens from the bottom of the unit.

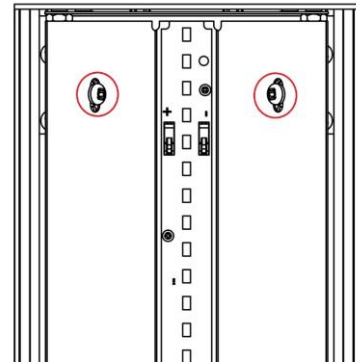

Step 2: For driver maintenance, first unscrew the reflector assembly.

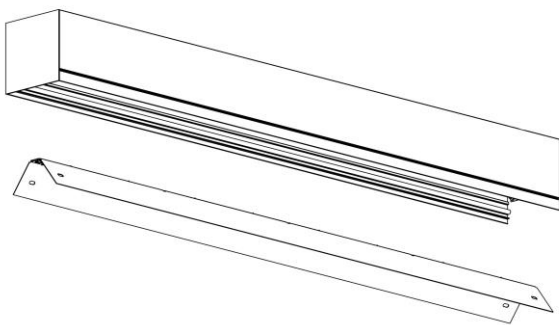

Step 3: Remove reflector assembly from unit.

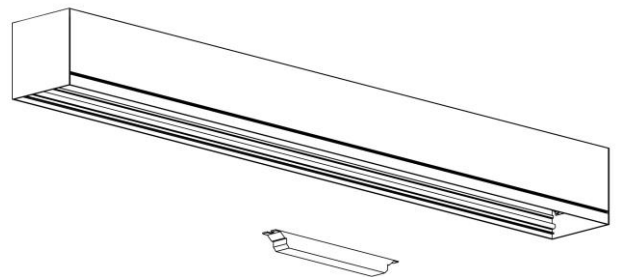

Step 4: Remove and service driver as required.