



NOTE: The following instructions provide general guidelines for product installation. These instructions apply to the 1x4 sized fixtures. For additional information consult the applicable electrical codes or contact factory directly for support before attempting anything with uncertainty.

WARNING: Risk of fire and electrical shock. DISCONNECT POWER AT ELECTRICAL PANEL before installing or servicing this product.

GENERAL SAFETY INSTRUCTIONS:

1. Read all instructions prior to installing this fixture.
2. Keep protective film/plastic on fixtures during installation to protect surface from damage or dirt.
3. This product must be installed in accordance with the applicable installation code by a person familiar with the construction and operation of the product and the hazards involved.
4. All wiring must be performed by a qualified electrician in accordance with national and local building and electrical codes.
5. This fixture must be suitably grounded for your protection against shock hazards and to assure proper operation.
6. Make sure that the power source conforms to the requirements of this fixture.
7. This product has accessible output terminals. Based on Canadian Electrical Code for class 2 circuits, this product requires installation in Restricted Access Area, so that no live parts are accessible to unauthorized persons.

PARTS LIST

- A. Back of Luminaire enclosure
- B. Powered Aircraft Cable
- C. Canopy
- D. Back Plate
- E. Aircraft Cable Gripper

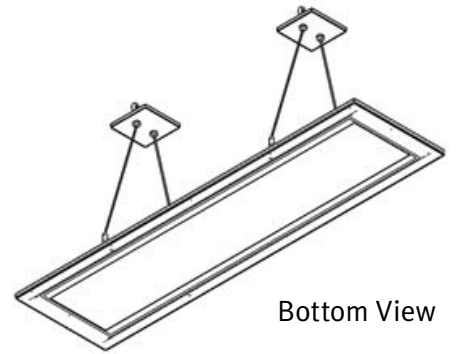
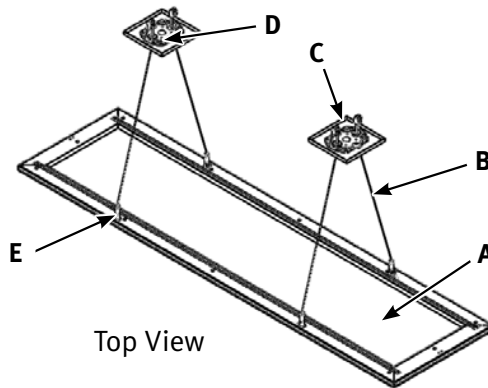

WIRING DIAGRAMS

FIXTURE TO REMOTE DRIVER BOX

WIRE ENTRY POWER AC (REMOTE DRIVER)



REMOTE DRIVER BOX TO LINE VOLTAGE

WIRE ENTRY 5 LEADS



INSTALLATION STEPS

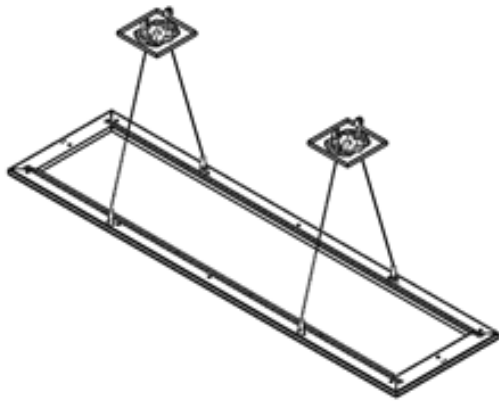

STEP 1. Remove fixture and all supplied parts from packaging. **DO NOT REMOVE** the protective film from the front surface of the fixture.

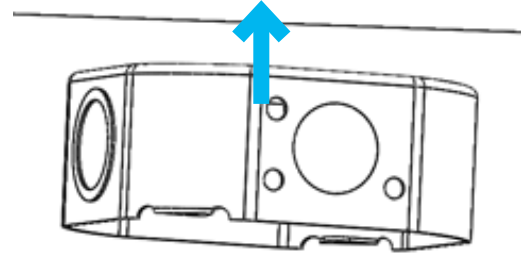

STEP 2. Secure Hex-Box (supplied by others) to a structure of suitable strength to support the fixture.

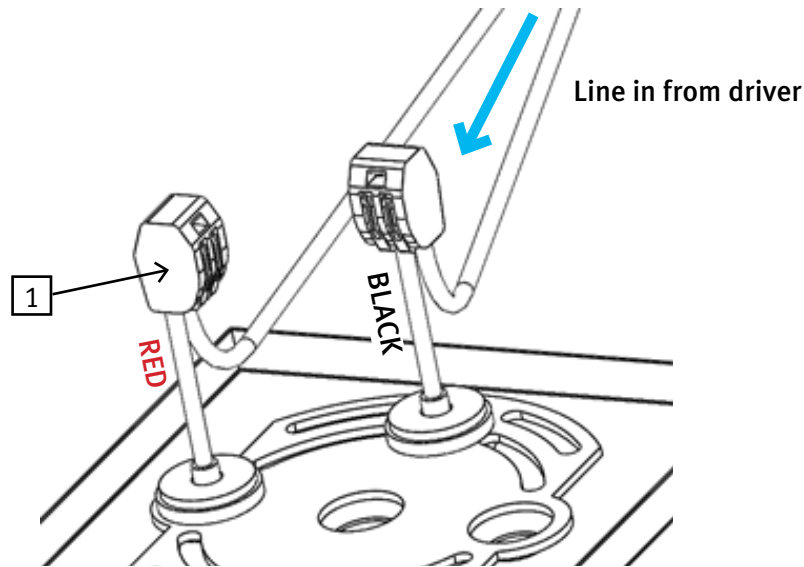

STEP 3. Connect black/red powered aircraft cable to line from the driver via the WAGO [1] or a similar electric connector. Refer to wiring diagram on page 2.

NOTE: The 1x4 fixture can have 2 powered canopies or 1 non-powered hanger canopy and 1 powered canopy.

STEP 4. Connect remote driver box to line voltage. Refer to wiring diagram on page 2.

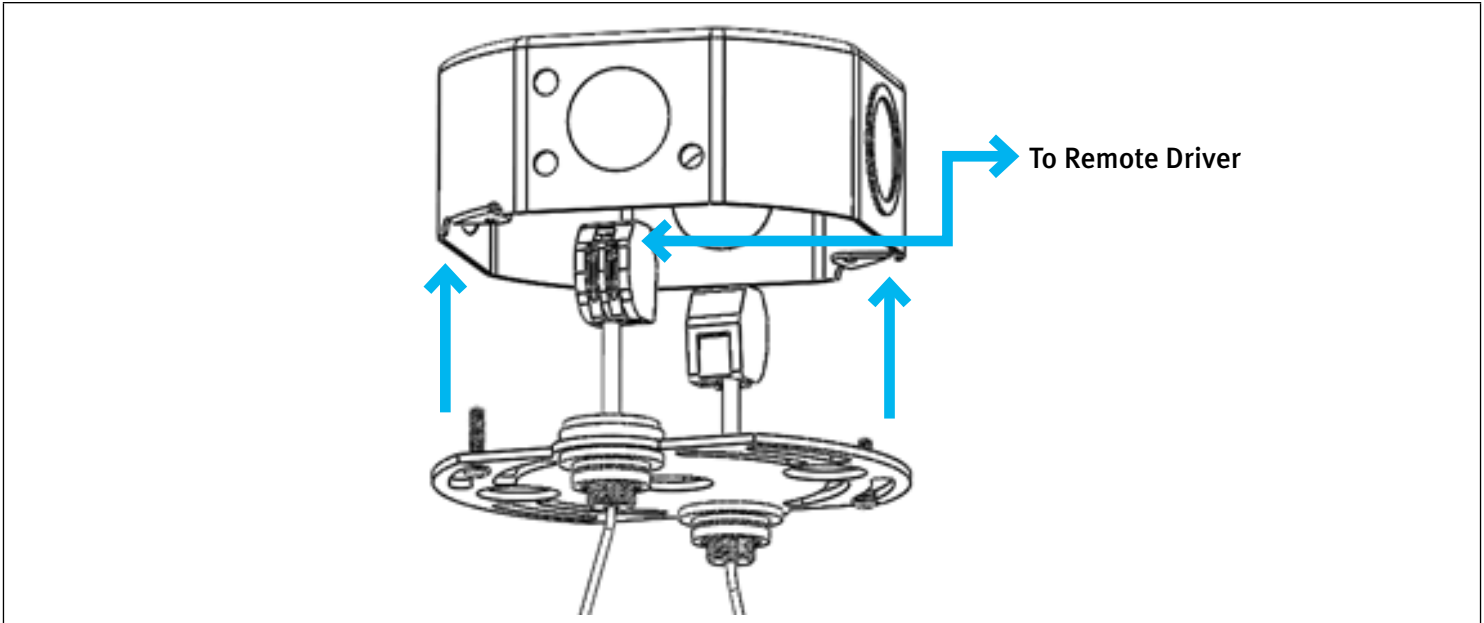

STEP 5. Remove end caps and lower canopy towards the fixture. Attach baseplate to the hex-box.

NOTE: Raise fixture so as to provide enough slack in the cables to be able to lower the canopy

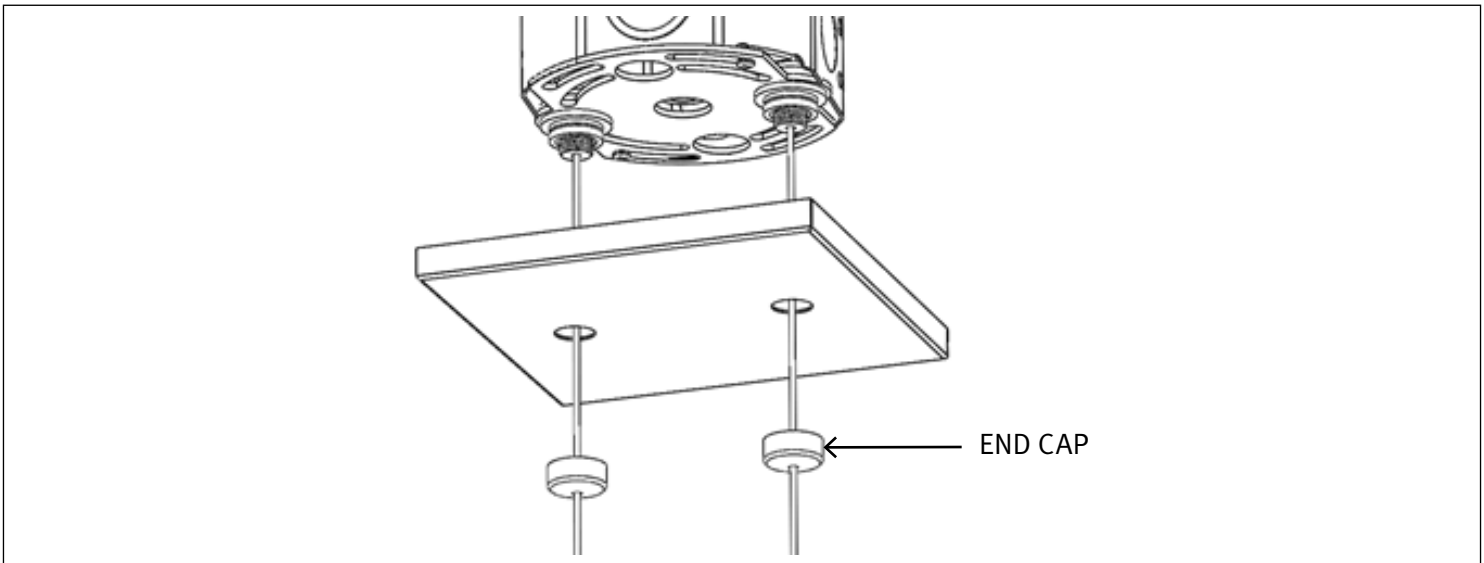

STEP 6. Raise canopy towards ceiling and attach to base plate using 4 end caps.

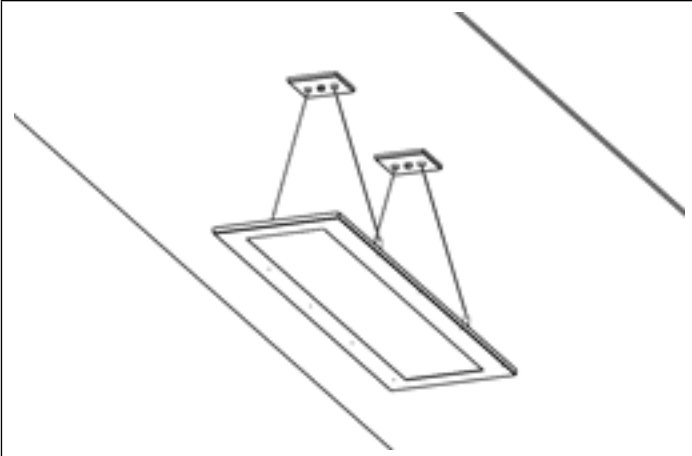

7. Remove protective film from the front surface of the light fixture when installation is completed.

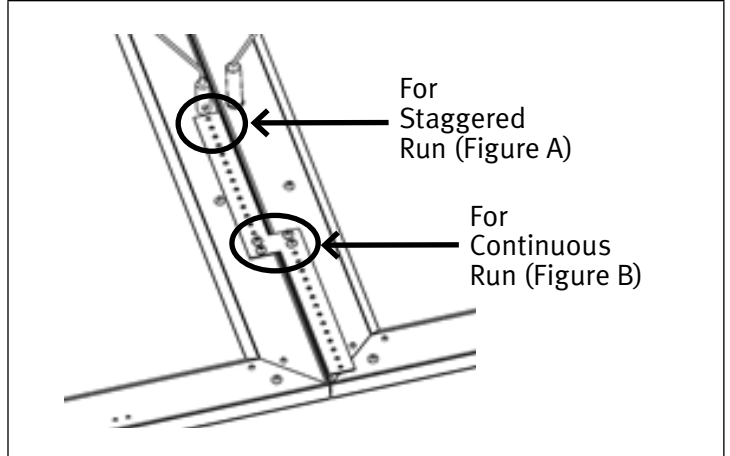

8. To create continuous chain, attach fixtures together using pendant connector bracket. Secure using screws.

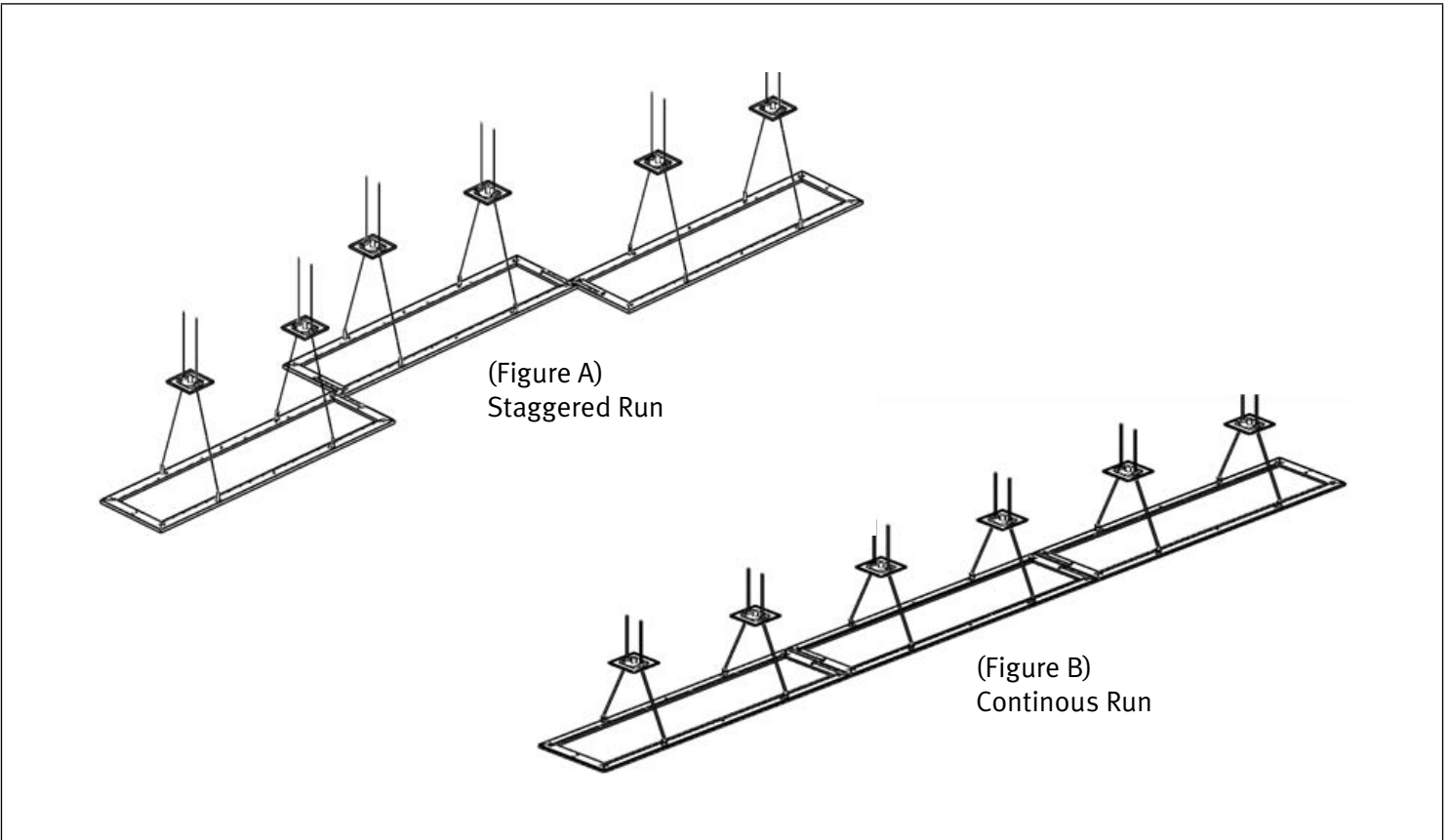

MAINTENANCE

REQUIRED TOOLS:

Plastic/Latex
Gloves



Screwdriver



IMPORTANT: use clean gloves to avoid adding oil/dirt to optics. Avoid scratching optics by using installation tools with soft plastic rounded edges.

TO CLEAN THE OPTICS:

Gently wipe down the optics with a clean, dry cloth to remove any dust and light residues. For heavier smudges, spray clean cloth with mild soap and water solution and gently wipe optics surface.

WARNING: Hard wiping and abrasive cloths will scratch the optics. DO NOT USE cleaning products containing alcohol or acetone which will damage the optics