

NOTE: The following instructions provide general guidelines for product installation. For additional information consult the applicable electrical codes or contact factory directly for support before attempting anything with uncertainty.

CAUTION: Do not assemble fixture runs on floor.

WARNING: Risk of fire and electrical shock. **DISCONNECT POWER AT ELECTRICAL PANEL** before installing or servicing this product.

GENERAL SAFETY INSTRUCTIONS:

1. Read all instructions prior to installing this fixture.
2. This product must be installed in accordance with the applicable installation code by a person familiar with the construction and operation of the product and the hazards involved.
3. All wiring must be performed by a qualified electrician in accordance with national and local building and electrical codes.
4. This fixture must be suitably grounded for your protection against shock hazards and to assure proper operation.
5. Make sure that the power source conforms to the requirements of this fixture.

Specifications and design subject to change without notice.

PARTS LIST

MAIN PARTS

- A. Luminaire Enclosure
- B. Lens
- C. End Cap
- D. Aircraft Cable
- E. Canopy
- F. Hanger Bracket
- G. Power Cord

OTHER PARTS

- Reflector/LED board assembly

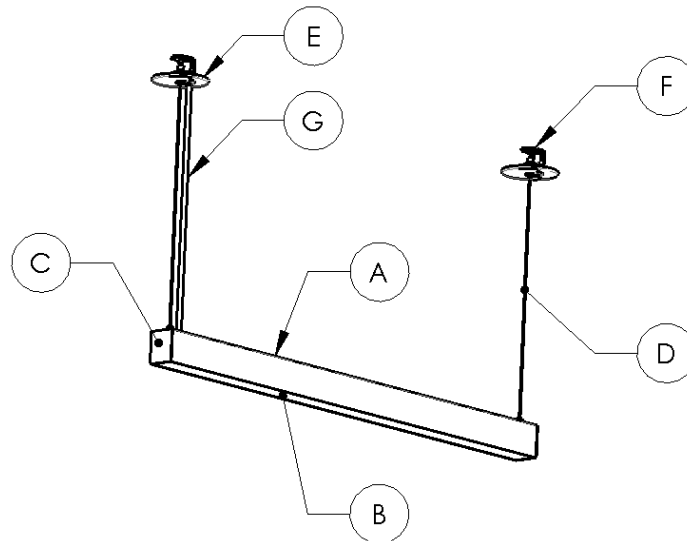

REQUIRED TOOLS

DRILL	#8 PHILLIPS BIT	#8 PHILLIPS SCREWDRIVER

WIRING DIAGRAMS

STANDARD WIRING

WITH OPTIONAL EMERGENCY CIRCUIT

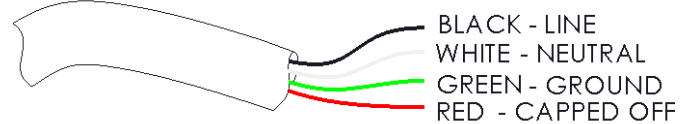

(18-4) POWER WIRE ENTRY

Specifications and design subject to change without notice.

WITH OPTIONAL BATTERY PACK

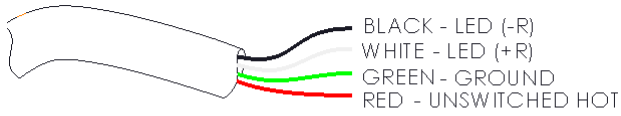

(18-4) BATTERY WIRE ENTRY

Specifications and design subject to change without notice.

STEP-BY-STEP INSTRUCTIONS

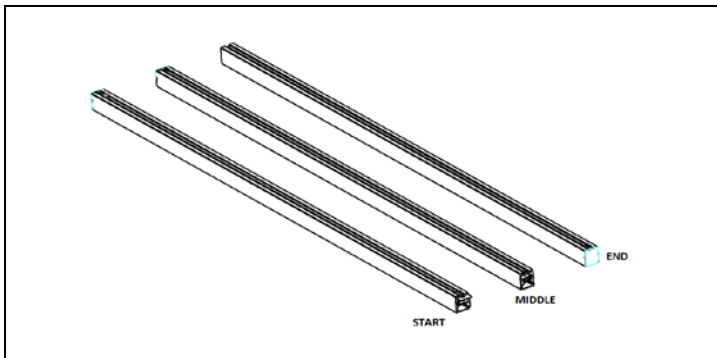

STEP 1. Remove fixture packaging; note marked supply wires coming out at the back of the luminaire.

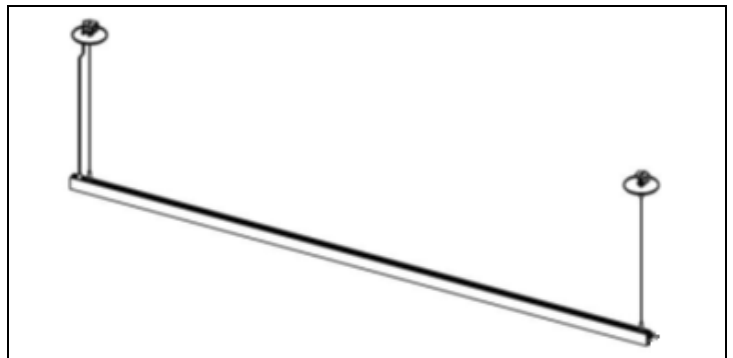

STEP 2. Install Start fixture first (as per standard installation instructions). Do not apply power.

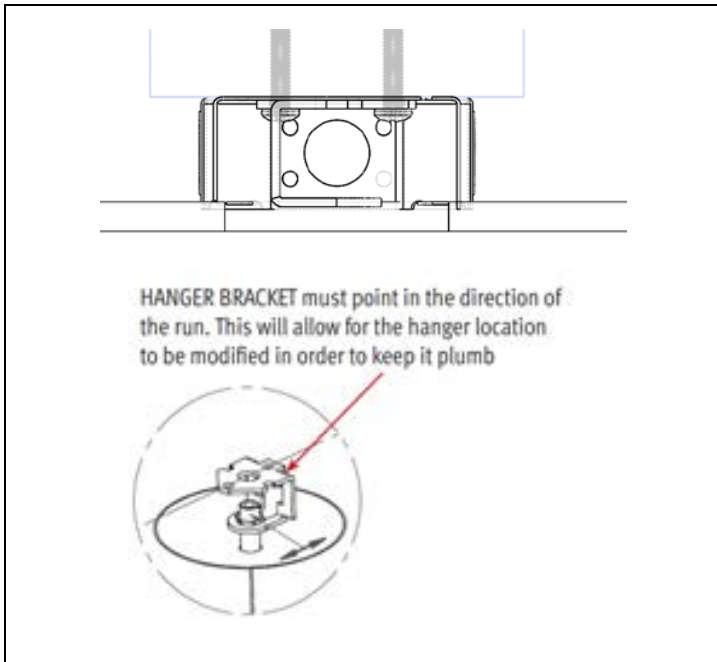

STEP 3. Install hanger brackets for the next fixture. Ensure bracket orientation is pointed along the run direction to allow for adjustment.

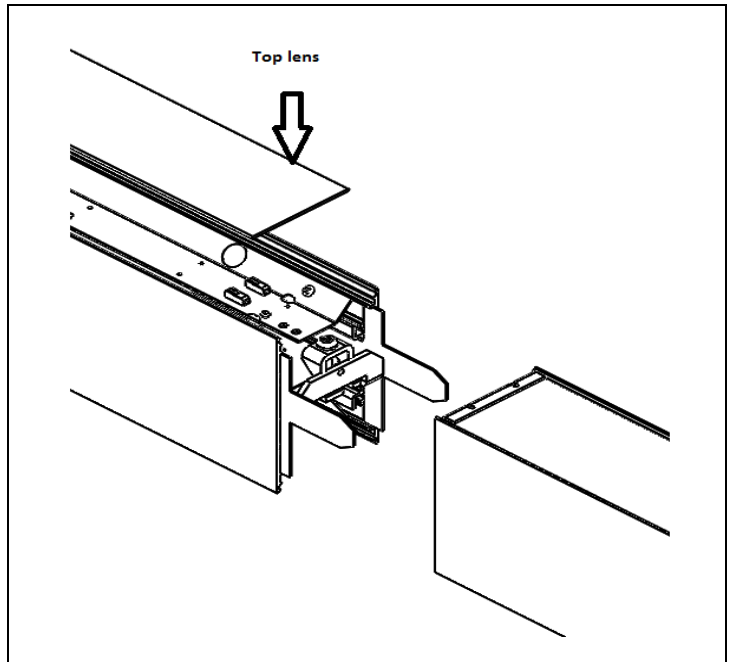

STEP 4. Remove the lens on the indirect side from the Start, Mid or End unit if there is no clearance for the #8 Philips driver

Specifications and design subject to change without notice.

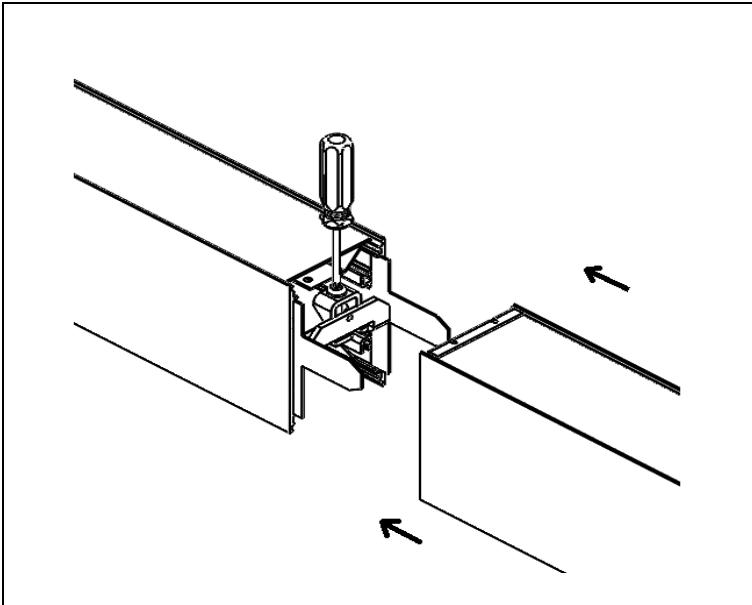

STEP 5. Align the mid/end fixture to the joint, slide it into place over the aligner bracket. Use a #8 Philips driver to tighten the screw as shown. Ensure the wedge is at the top to clear the tongue of the fixture you are trying to join.

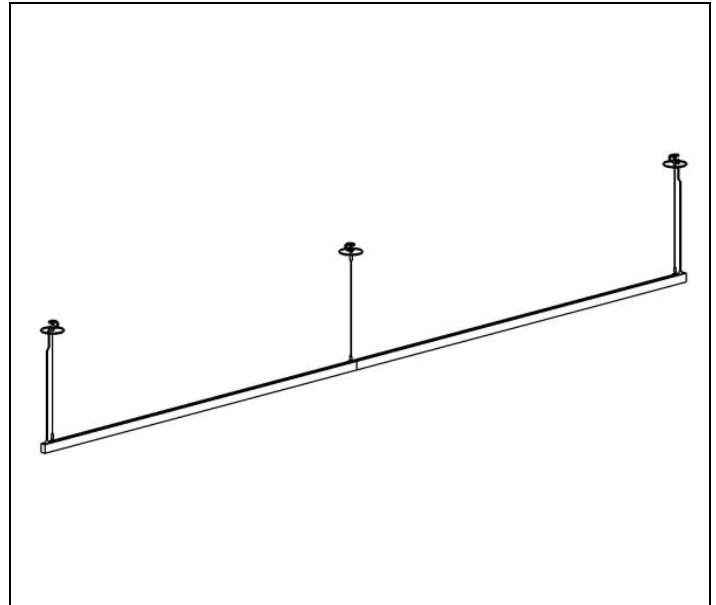

STEP 6. Continue to follow Steps 1-3 to complete the run, mounting hangers as necessary. Perform wiring between fixtures. Reinstall all parts. Example of a completed run.

Specifications and design subject to change without notice.