

RAIL 4 RM4DOD

OUTDOOR . LED . MULLION . DIRECT

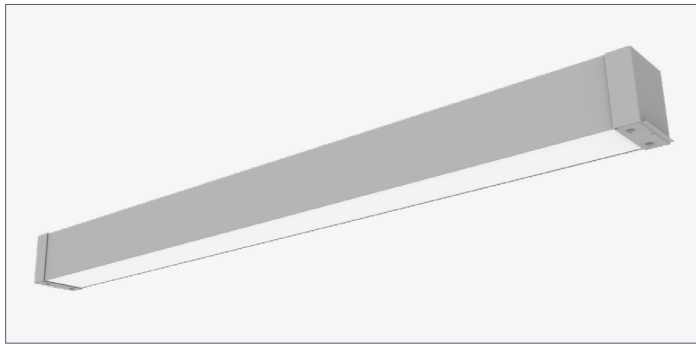

PART #:	
PREP BY:	DATE:
PROJECT:	
NOTES:	
APPROVAL SIGNATURE:	DATE (DD/MM/YYYY):

PERFORMANCE SUMMARY @ 3500K

		Meta Blanc (MB)	Meta Ice (M)
		L3	L3
Lumens per foot	80 CRI	586	653
	90 CRI	513	571
Wattage per foot		6.1	6.1
Efficacy (lm/W)	80 CRI	97	108
	90 CRI	84	94
L70 Estimate (h)		≥ 60,000 hrs	

See page 2 for the complete Light Level Performance chart.

FEATURES

- Efficacy up to 110 lm/W
- Suitable for outdoor, wet locations
- Standard natatorium finish
- Indirect distribution available with Inverse Mounted option
- Emergency lighting

ORDERING LOGIC

Example Part Number: RM4DOD-1L35K-8-MB-W-L31-M-1-90

1. SERIES	2. COLOR TEMP	3. LENGTH	4. PATTERN ¹	5. OPTICS	
RM4DOD	1L30K 3000K 1L35K 3500K 1L40K 4000K	2 2 ft 3 3 ft 4 4 ft 5 5 ft 6 6 ft 7 7 ft 8 8 ft 9 9 ft 10 10 ft 11 11 ft 12 12 ft RA Continuous Rows (Replace "A" with length in feet) C Custom Length* _ None (leave space empty)	GA Square GAxB Rectangle UAxBxC U-Shape LAxB L-Shape _ None (leave space empty) Standard Pattern Minimum Lengths Replace "A", "B", "C" with length in feet. See minimum lengths below	MB Meta Blanc M Meta Ice MA Meta Ice w/ Asymmetric Reflector Meta Blanc: Opal diffuse lens Meta Ice: High output semi-diffuse lens	
90 CRI is available under OPTIONS					
6. FINISH	7. LIGHT LEVEL / DRIVER	8. CIRCUITRY	9. MOUNTING	10. VOLTAGE	11. OPTIONS
SA Satin Aluminum W White B Black C Custom Finish Specify RAL:	L1 Select Driver below. L2 See Light Level Performance chart on p2. L4	1 1 Circuit EM Emergency / Night Light (not available for 2ft) B Emergency Battery Pack ² (Battery option is limited to ambient temperatures above 0°C)	M Mullion Mounted	1 120 V 2 277 V 3 347 V 4 UNV (120 - 277V)	90 90 CRI, High R9 IM Inverse Mounted SP Surge Protection EF End Feed (Alone fixtures only) _ None (leave space empty)

*Consult factory. | ¹ Pattern record drawings showing mounting locations will be sent out upon order. | ² Battery operates 4ft sections only.

Select Driver:

- Factory option 0-10V, 1% Dimming
- LHE** Lutron H-Series Hi-lume 1% EcoSystem LED Driver
- LA2** Lutron A-Series Hi-lume 1% 2-wire LED Driver
- L5E** Lutron 5-Series EcoSystem LED Driver

Light Level Performance

3500K, 80 CRI, 0-10V Dimming (Standard)

Optics	Meta Blanc (MB)			Meta Ice (M)		
	Lumens per foot	Wattage per foot	Efficacy (lm/W)	Lumens per foot	Wattage per foot	Efficacy (lm/W)
L1	345	3.5	98	384	3.5	110
L2	431	4.4	97	481	4.4	109
L3	586	6.1	97	653	6.1	108
L4	1088	12.5	87	1214	12.5	97

Lumen Adjustment Factor

Color Temp	80 CRI	90 CRI
3000K	0.984	0.880
3500K	1.000	0.875
4000K	1.032	0.879

Metalumen's light level performance metrics are subject to manufacturers component tolerances.

CROSS SECTIONS

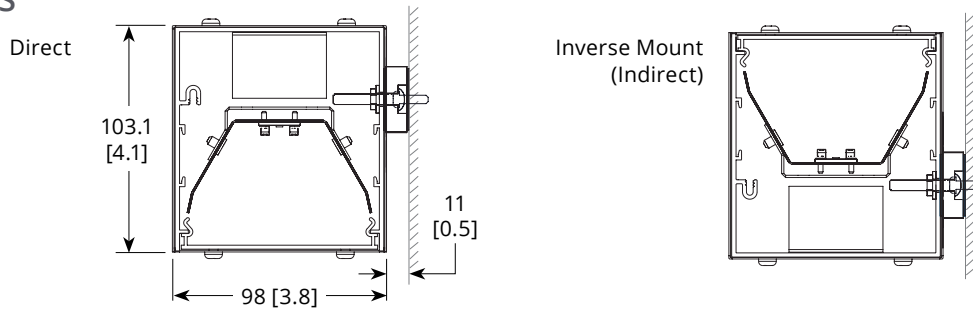

BLOCK MOUNTING DETAIL

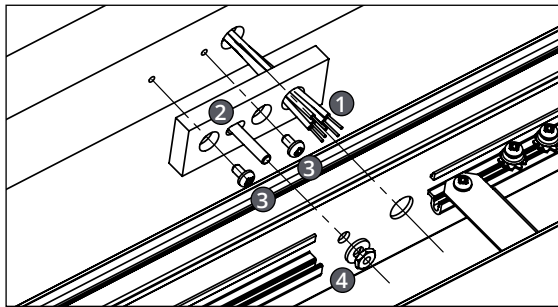

- Step 1**
Feed Power through the wire entry hole in the Mullion block and connect power within the Luminaire.
- Step 2**
Insert Carriage bolt in to Mullion Block before Fastening Block to Wall.
- Step 3**
Fasten the Mullion Block to the wall with fasteners by others.
- Step 4**
Attach Luminaire to the Mullion block by securing the Luminaire Mount nut onto the carriage bolt inside the Luminaire.

SPECIFICATIONS

Due to the Continuous Improvement Policy at Metalumen, we reserve the right to change our specifications without notice.

Housing: Rigid extruded aluminum body, 2.0mm (0.08") nominal wall thickness. Aluminum formed end caps.
Optical System: Metalumen luminaires are designed to utilize leading edge LED technology combined with luminaire optimized reflectors and our custom diffusers, resulting in industry leading optical performance.
CRI: 83+ for 3500K, 80 minimum for all

CCTs in standard configurations.
Lumen Maintenance: Minimum 50,000h with TM-21 lumen maintenance of 85% @ 25°C ambient temperature (calculated based on IESNA LM-80-08 LED test data). L70: ≥ 60 000hrs.
Finish: White, satin aluminum or black paint with a natatorium finish is standard. For custom paint with natatorium finish, please contact

factory.
Weight: 2.1 kg/300mm [4.6 lb/ft]
Mounting: Mullion mount bracket provided. Inverse mounting option is suitable for exterior use with full overhead coverage similar to canopy. Not acceptable for direct sky or extreme weather conditions.
Drivers: Metalumen offers dimming drivers as a standard on our entire LED product offering at 0-10V.

Dimming range is 10%-100%. Power factor is > 90%. Class 2 rating. Drivers are integral.
Approvals: All components are UL/ CSA/QPS recognized or listed. RoHS compliant. cULus listed.
Environment: Suitable for wet locations -22°F / -30°C start ambient temperature. Suitable for natatorium environments.

WARRANTY

Metalumen will warrant defective luminaires for 5 years from date of purchase. Warranty is valid if luminaire is installed and used according to specification. If defective, Metalumen will send replacement boards or drivers at no cost along with detailed replacement instructions and instructions on how to return defective components to Metalumen.

PHOTOMETRIC DATA - 3500K, 80 CRI

Optics: **Meta Blanc**
 IES File: **RM4DOD-1L35K-4-MB-L3**
 Lumens: **586/ft** Wattage: **6.1/ft**
 Efficacy: **97 lm/W**

ZONAL LUMEN SUMMARY

Zone	Lumens	%Fixt
0-20	392	16.7
0-30	802	34.1
0-40	1255	53.4
0-60	2002	85.2
0-80	2325	99
0-90	2350	100
10-90	2245	95.5
20-40	862	36.7
20-50	1280	54.5
40-70	966	41.1
60-80	323	13.7
70-80	105	4.5
80-90	25	1
90-110	0	0
90-120	0	0
90-130	0	0
90-150	0	0
90-180	0	0
110-180	0	0
0-180	2350	100

PHOTOMETRIC CURVE
 100% Down

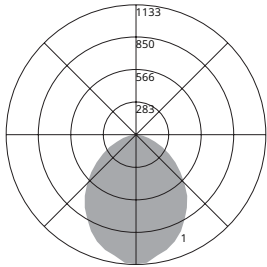

COEFFICIENTS OF UTILIZATION

Zonal Cavity Method | Effective Floor Cavity Reflectance = .20

RC	80				70				50			
	RW	70	50	30	10	70	50	30	10	50	30	10
RCR												
0	119	119	119	119	116	116	116	116	111	111	111	111
1	110	106	102	98	107	103	100	97	99	96	94	94
2	101	94	87	82	98	92	86	81	88	83	79	79
3	93	83	76	70	90	82	75	69	79	73	68	68
4	86	74	66	60	83	73	66	60	71	64	59	59
5	79	67	59	53	77	66	58	52	64	57	52	52
6	73	61	52	46	72	60	52	46	58	51	46	46
7	68	56	47	41	67	55	47	41	53	46	41	41
8	64	51	43	37	62	50	43	37	49	42	37	37
9	60	47	39	34	58	46	39	34	45	38	34	34
10	56	44	36	31	55	43	36	31	42	35	31	31

LUMINANCE DATA (CD/M²)

Vertical Angle	Horizontal Angle		
	0	45	90
45	5964	3188	2456
55	4975	2249	1673
65	3889	1405	1013
75	2552	693	475
85	1012	150	94

CANDELA DISTRIBUTION

Vertical Angle	Horizontal Angle				
	0	22.5	45	67.5	90
0	1128	1128	1128	1128	1128
5	1117	1118	1095	1105	1133
10	1069	1082	1067	1065	1063
15	1038	1032	1014	1014	1002
20	988	977	970	942	939
25	927	916	890	867	854
30	848	842	815	785	768
35	775	761	718	690	674
40	694	679	625	594	575
45	598	585	540	498	475
50	507	496	445	411	399
55	418	402	369	333	321
60	333	318	289	259	251
65	253	242	216	196	187
70	177	170	153	137	130
75	113	110	96	86	82
80	61	57	50	44	41
85	22	22	18	15	14
90	6	4	2	2	2

Optics: **Meta Ice**
 IES File: **RM4DOD-1L35K-4-M-L3**
 Lumens: **653/ft** Wattage: **6.1/ft**
 Efficacy: **107 lm/W**

ZONAL LUMEN SUMMARY

Zone	Lumens	%Fixt
0-20	425	16.2
0-30	874	33.4
0-40	1376	52.6
0-60	2222	84.9
0-80	2589	99
0-90	2617	100
10-90	2504	95.7
20-40	951	36.4
20-50	1422	54.3
40-70	1094	41.8
60-80	367	14
70-80	119	4.6
80-90	27	1
90-110	0	0
90-120	0	0
90-130	0	0
90-150	0	0
90-180	0	0
110-180	0	0
0-180	2617	100

PHOTOMETRIC CURVE
 100% Down

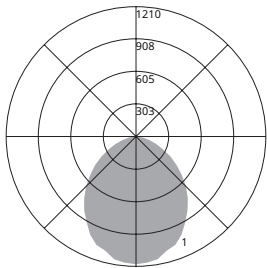

COEFFICIENTS OF UTILIZATION

Zonal Cavity Method | Effective Floor Cavity Reflectance = .20

RC	80				70				50			
	RW	70	50	30	10	70	50	30	10	50	30	10
RCR												
0	119	119	119	119	116	116	116	116	111	111	111	111
1	110	106	102	98	107	103	100	97	99	96	94	94
2	101	93	87	82	98	91	86	81	88	83	79	79
3	93	83	75	69	90	81	74	69	78	72	68	68
4	85	74	66	60	83	73	65	59	70	64	58	58
5	79	67	58	52	77	66	58	52	64	57	51	51
6	73	60	52	46	71	60	52	46	58	51	45	45
7	68	55	47	41	66	54	46	41	53	46	41	41
8	63	51	42	37	62	50	42	37	49	42	37	37
9	59	47	39	33	58	46	38	33	45	38	33	33
10	56	43	36	31	55	43	35	30	42	35	30	30

LUMINANCE DATA (CD/M²)

Vertical Angle	Horizontal Angle		
	0	45	90
45	6545	3620	2858
55	5509	2549	1964
65	4256	1626	1180
75	2927	784	558
85	1113	168	103

CANDELA DISTRIBUTION

Vertical Angle	Horizontal Angle				
	0	22.5	45	67.5	90
0	1186	1186	1186	1186	1186
5	1175	1210	1197	1189	1195
10	1157	1144	1158	1179	1157
15	1099	1114	1108	1095	1105
20	1072	1059	1054	1032	1049
25	1005	990	986	954	957
30	918	920	899	870	855
35	837	829	805	773	768
40	750	737	712	676	658
45	657	647	613	575	553
50	557	549	510	474	465
55	463	451	418	387	377
60	369	357	329	302	296
65	277	272	250	227	218
70	200	192	175	158	149
75	130	122	109	97	96
80	67	64	57	50	47
85	25	24	20	17	16
90	6	4	2	2	2

Photometric performance is measured and scaled in accordance with IESNA LM-79.