

**NOTE:** The following instructions provide general guidelines for product installation. For additional information consult the applicable electrical codes or contact factory directly for support before attempting anything with uncertainty.

**CAUTION:** Do not assemble fixture runs on floor.

**WARNING:** Risk of fire and electrical shock. **DISCONNECT POWER AT ELECTRICAL PANEL** before installing or servicing this product.

**GENERAL SAFETY INSTRUCTIONS:**

1. Read all instructions prior to installing this fixture.
2. This product must be installed in accordance with the applicable installation code by a person familiar with the construction and operation of the product and the hazards involved.
3. All wiring must be performed by a qualified electrician in accordance with national and local building and electrical codes.
4. This fixture must be suitably grounded for your protection against shock hazards and to assure proper operation.
5. Make sure that the power source conforms to the requirements of this fixture.

Specifications and design subject to change without notice.

PARTS LIST

**MAIN PARTS**

- A. Luminaire Enclosure
- B. Lens

**OTHER PARTS**

- Reflector/LED board assembly
- Driver and Driver Enclosure assembly
- Power Cord

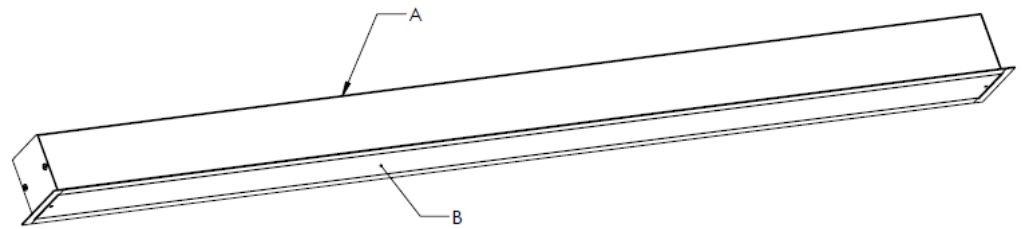

Specifications and design subject to change without notice.

**REQUIRED TOOLS**

DRILL	#8 PHILLIPS BIT	#8 PHILLIPS SCREWDRIVER	WRENCH
			

**Important:** Use clean gloves to avoid adding oil/dirt to optics surface. Avoid scratching optics by using installation tools with soft plastic rounded edges

**WIRING DIAGRAMS**

**STANDARD WIRING**

(18-6)

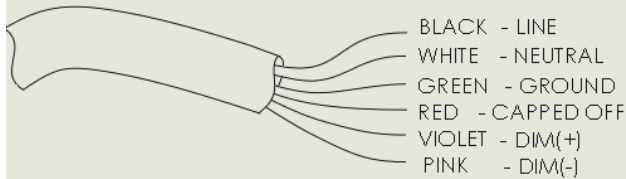

Specifications and design subject to change without notice.

STEP-BY-STEP INSTRUCTIONS

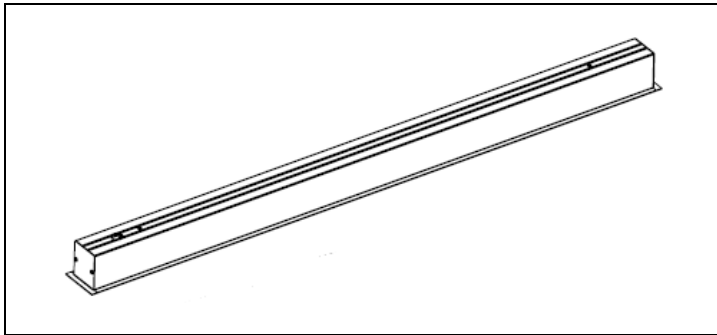

**STEP 1.** Remove fixture packaging.

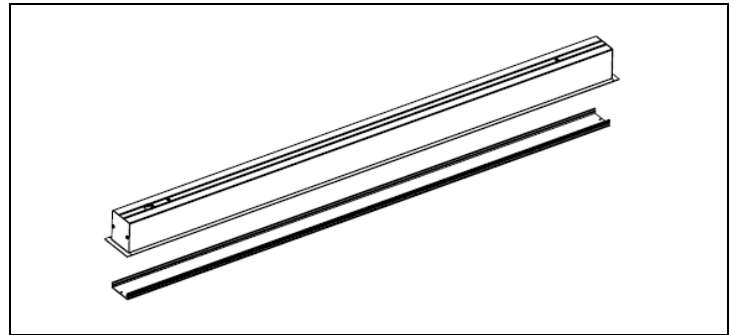

**STEP 2.** Remove the lens from the fixture.

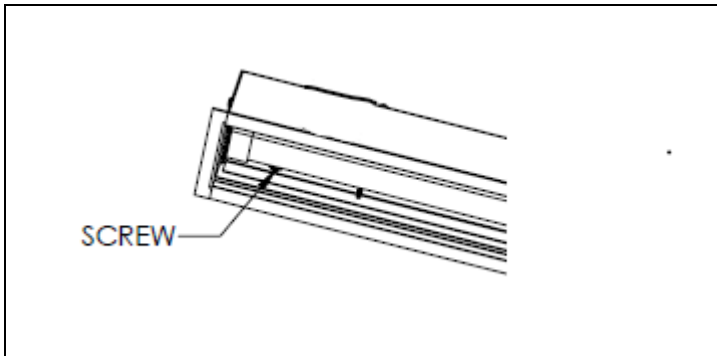

**STEP 3.** Remove screws from the reflector assembly.

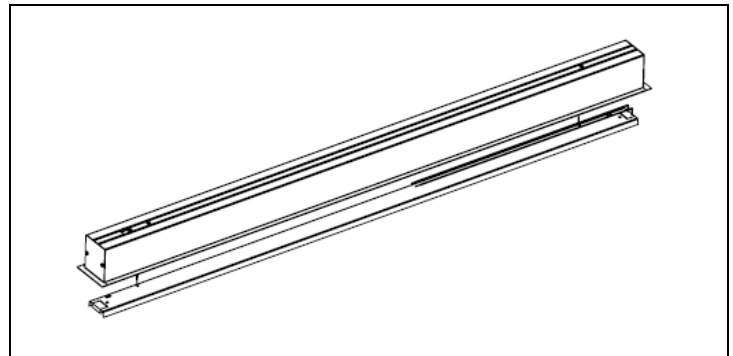

**STEP 4.** Lower the reflector assembly, hung on safety cable.

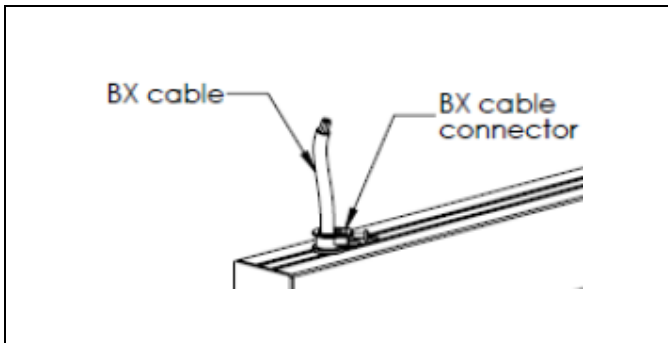

**STEP 5.** Install BX connector (supplied by others). Feed BX cable (supplied by others) through connector and the body enclosure. Tighten BX connector screw. Wire power cord to BX cable using waterproof wire nuts (supplied by others). Refer to provided wiring diagram.

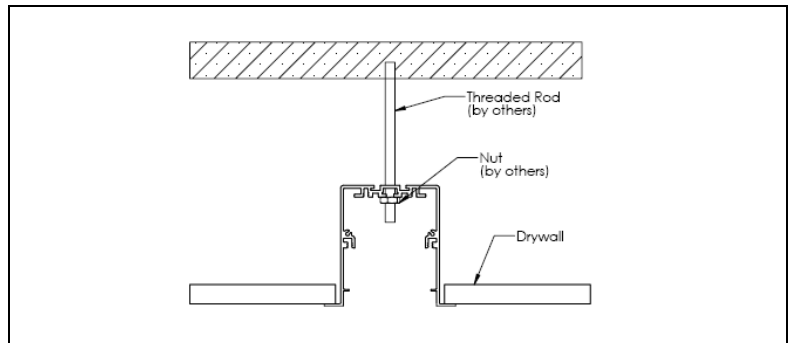

**STEP 6.** Feed threaded mounting rod (by others) through mounting locations. Insert the fixture all the way through the opening in the ceiling. Insert nut (by others) through the fixture and fasten the fixture in place. Repeat with remaining mounting locations. Reinstall reflector assembly and lens.

Specifications and design subject to change without notice.

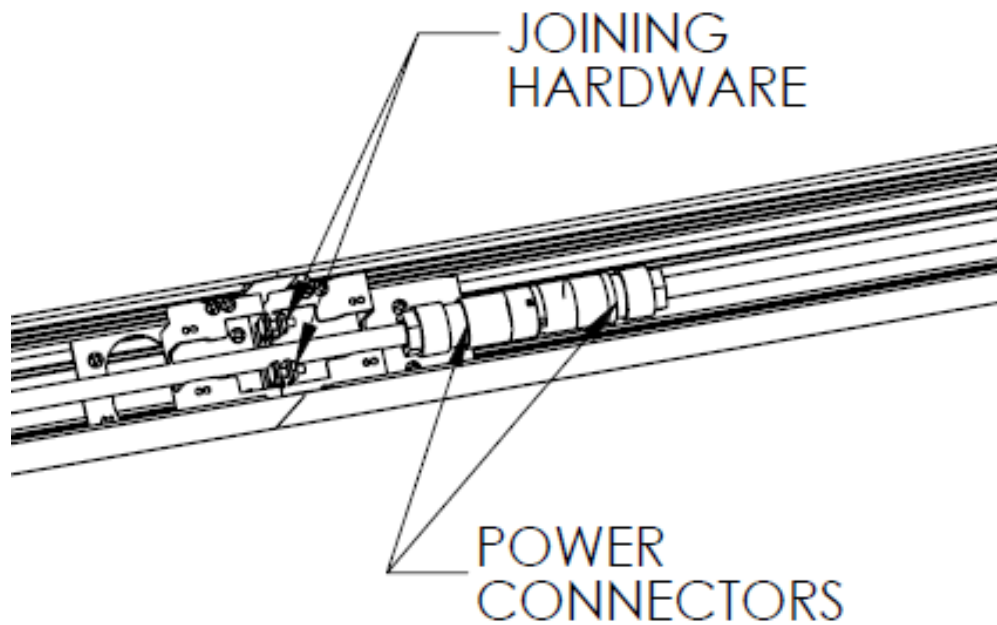

**STEP 7.** For continuous runs, install Start fixture first (as per steps 1-6). Do not apply power. Install joining fixture (as per steps 1-4). Align joining fixture and slide it into place, then follow step 6 to secure the fixture to threaded rod and then install the joining hardware. Then connect power connectors together. Reinstall reflector assembly and lens.

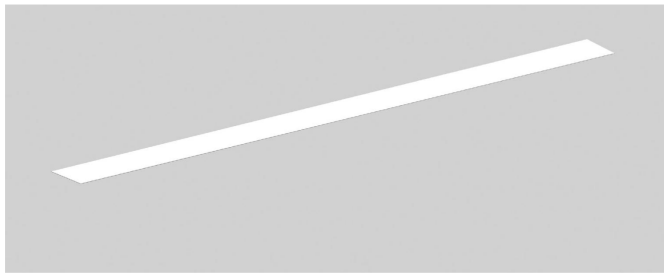

**STEP 8.** Installed fixture.

Specifications and design subject to change without notice.

## MAINTENANCE

### REQUIRED TOOLS:

- Plastic / Latex Gloves
- Screwdriver

**Important:** Use clean gloves to avoid adding oil/dirt to reflector surface. Avoid scratching reflector surface by using installation tools with soft plastic rounded edges.

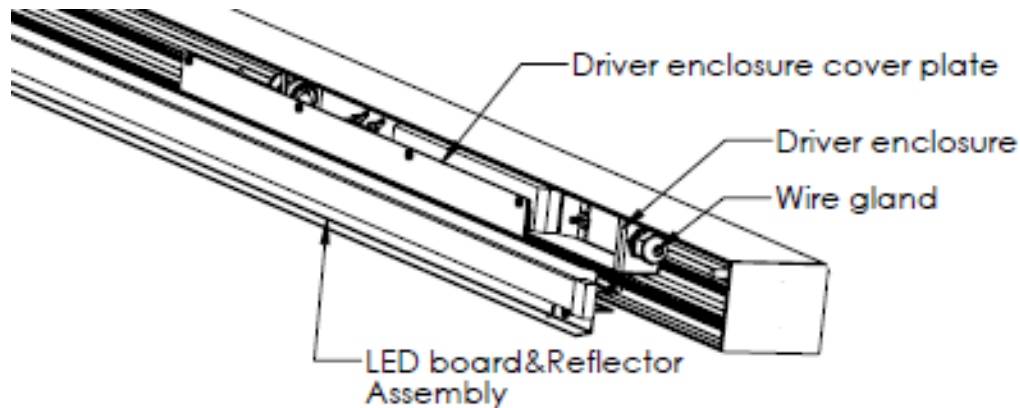

Remove lens from the unit. Remove screws from the reflector assembly. Lower the reflector assembly, hung on safety cable. Remove the screws and then remove the driver enclosure cover plate.

1. For LED board maintenance:  
Disconnect the wires from driver, loose the wire gland, disconnect the safety cable and then completely remove the entire LED board & Reflector Assembly. Install the new LED board & Reflector by installing the safety cables to body, passing the wires through the wire gland and tightening the wire gland. Then connect the wires to driver (Red to led+, blue to led-). Reinstall driver enclosure cover plate and then mount LED board & reflector assembly to fixture. Reinstall lens.
2. For driver maintenance:  
Remove and service driver as required. Be sure to wire correctly (both power and dimming, and the wires to LED board). Reinstall driver enclosure cover plate, ensure all wires are inside of the driver enclosure and then mount LED board & reflector assembly to fixture. Reinstall lens.

Specifications and design subject to change without notice.